

TECHNICAL MANUAL  
CALIBRATION PROCEDURE  
FOR  
DC POWER SUPPLIES

Distribution Statement - Distribution authorized to U. S. Government agencies and their contractors for official use or for administrative or operational purposes only, 30 August 1988. Other requests for this document shall be referred to AFMETCAL Detachment 1/MLLW, 813 Irving-Wick Dr W, Suite 4M, Heath, OH 43056-6116.

Destruction Notice - For unclassified, limited documents, destroy by any method that will prevent disclosure of the contents or reconstruction of the document.

Published under Authority of the Secretary of the Air Force

---

**30 JULY 2000**  
**CHANGE 1 - 30 JANUARY 2001**

# T.O. 33K1-4-1000-1

## LIST OF EFFECTIVE PAGES

INSERT LATEST CHANGED PAGES. DESTROY SUPERSEDED PAGES.

NOTE: The portion of the text and illustrations affected by the changes is indicated by a vertical line in the outer margins of the page.

Date of issue for original and changed pages are:

Original .....0..... 30 July 2000  
Change.....1..... 30 January 2001

TOTAL NUMBER OF PAGES IN THIS PUBLICATION IS 40, CONSISTING OF THE FOLLOWING:

Page No.	* Change No.	Page No.	* Change No.	Page No.	* Change No.
Title.....	1				
A.....	1				
1 - 8.....	0				
A-1 - A-2.....	1				
A-3 - A-18.....	0				
A-19.....	1				
A-20 - A-27.....	0				
A-28 - A-30.....	1				

\*Zero in this column indicates an original page

## DC POWER SUPPLIES

This procedure describes the calibration of Power Supplies listed in Appendix A and supersedes any and all previously dated calibration procedures for the subject instrument.

### 1 CALIBRATION DESCRIPTION:

*Table 1.*

Test Instrument (TI) Characteristics	Performance Specifications	Test Method
Voltmeter and Ammeter		
DC Voltmeter	Range: 0 to 500 VDC  Accuracy: As specified in Rating column of Appendix A	Monitored with a Digital Multimeter
DC Ammeter (Constant Voltage)	Range: 0 to 500 ADC  Accuracy: As specified in Rating column of Appendix A	Monitored with a Shunt Box and Digital Multimeter
DC Ammeter (Constant Current) * <sup>1</sup>	Range: 0 to 500 ADC  Accuracy: As specified in Rating column of Appendix A	Monitored with a Shunt Box and Digital Multimeter
Line and Load Regulation (Constant Voltage)	Line: See Appendix A  Accuracy: See Appendix A  Load: NL to FL  Accuracy: See Appendix A	Input voltage varied, output monitored with a Digital Multimeter
Ripple and Noise (Constant Voltage)	Range: See Appendix A  Accuracy: See Appendix A	Measured with Digital Multimeter or Oscilloscope
Line and Load Regulation (Constant Current) * <sup>1</sup>	Line: 105 to 125 VAC or as listed in Appendix A  Accuracy: See Appendix A  Load: NL to FL  Accuracy: See Appendix A	Input voltage varied, output monitored with a Shunt Box and Digital Multimeter
Ripple (Constant Current) * <sup>1</sup>	Range: See Appendix A  Accuracy: See Appendix A	Measured with Digital Multimeter or Oscilloscope

\*<sup>1</sup> Current Calibration limited to 300 ADC due to equipment capability. See step 3.2.

**2 EQUIPMENT REQUIREMENTS:**

Noun	Minimum Use Specifications	Calibration Equipment	Sub-Item
2.1 DIGITAL MULTIMETER	Range: 0 to 500 VDC; 40 $\mu$ V to 300 mV AC, 60 Hz	Fluke 8840A/AF	
	Resolution: 100 $\mu$ V DC; 10 $\mu$ V AC		
	Accuracy: $\pm 0.0325\%$ of rdg, VDC; N/A, VAC		
2.2 DIGITAL MULTIMETER	Range: 0 to 500 VDC	Hewlett-Packard 3458A	
	Resolution: 10 $\mu$ V DC		
	Accuracy: $\pm 0.03\%$ of rdg, VDC		
2.3 MULTIMETER	Range: 105 to 125 VAC	Fluke 87	
	Accuracy: $\pm 2.5\%$ of rdg		
2.4 VARIAC	Range: Single phase, 105 to 125 or 207 to 253 VAC at rated line current for TI being calibrated	As Available	
	Accuracy: N/A		
2.5 VARIAC	Range: Three phase, 190 to 250 VAC at rated line current for TI being calibrated	As Available	
	Accuracy: N/A		
2.6 SHUNT BOX	Range: 0 to 300 ADC	Guildline 9211A	
	Accuracy: $\pm 0.07\%$ of setting		
2.7 SPST SWITCH	Range: Must be capable of carrying up to 300 ADC	As Available	
	Accuracy: N/A		
2.8 OSCILLOSCOPE	Range: 50 MHz, bandwidth; 1.0 mV p-p to 1.5 V p-p, voltage range	Tektronix 2465B	
	Accuracy: Min p-p value being verified in 4.3		

<b>Noun</b>	<b>Minimum Use Specifications</b>	<b>Calibration Equipment</b>	<b>Sub-Item</b>
2.9 VARIABLE LOAD RESISTOR	Range: See step 4.1.2 Accuracy: N/A	As Available	
2.10 LOAD BANK	Range: 30 VDC at 100 A Accuracy: N/A	Avtron Mfg T242B	

### **3 PRELIMINARY OPERATIONS:**

3.1 Review and become familiar with the entire procedure before beginning the Calibration Process.



Unless otherwise designated, and prior to beginning the Calibration Process, ensure that all test equipment voltage and/or current outputs are set to zero (0) or turned off, where applicable. Ensure that all equipment switches are set to the proper position before making connections or applying power.



This Calibration Procedure contains steps whereby voltages up to 500 VDC, 230 VAC and currents up to 50 Amps are present on open terminals and contacts. Care must be exercised not to come in contact with these terminals and contacts if the TI is operated with the nonconductive terminal cover removed.

3.2 Current Calibration is limited to 300 ADC due to equipment capability. A Limited Certification Label must be used, annotated: Current Limited to 300 Amps due to test equipment limitations.

3.3 Mechanically zero TI meter/meters, if necessary.

3.4 Connect the TI and test equipment to appropriate power source, set POWER switches to ON and allow warm-up as required by manufacturer.

3.5 Customer must determine if both front and rear output terminals are to be used. As appropriate, calibrate both sets of output terminals or use a Limited Certification Label to limit use to the set of output terminals calibrated.

3.6 Some TIs with front and rear output terminals may have only one output designed to meet Accuracy specifications stated by the manufacturer. Consult maintenance T.O. or manufacturer data to determine if Accuracy specifications apply to both front and rear terminals. When commercial/maintenance data indicates which terminals have the listed specifications, a Limited Certification Label is not required, however, the special block on the Certification Label will be annotated with which terminals were certified.

3.7 Certain equipment listed in Appendix A is operated from power line voltages other than 115 VAC, 60 Hz. Substitute 230 VAC, 60 Hz in all steps and figures for any TI requiring 230 VAC, 60 Hz input.

3.8 If applicable, connect jumpers across appropriate sensing terminals on back of TI for proper operation.

3.9 Some TIs have both Constant Voltage and Constant Current characteristics, others have one or the other. Use characteristics as stated in Appendix A or as required by the user for model being calibrated. Use only these portions of the TI being calibrated.

3.10 Some TIs have meters with full scale markings higher than the rating. Do not exceed these rating specifications. Accuracy limits must be computed using the full scale value for the applied rating value (i.e., 50 V  $\pm 2\%$  FS = 1 V, 40 V rating, limits 39 to 41 on Digital Multimeter (2.1)).

3.11 Some TIs have more than one range on their meters. Applicable section of procedure should be repeated for the other range/ranges with the applicable control switch/switches set to the appropriate position.

3.12 Ensure TI fuses are of the proper value, if applicable, before beginning calibration.

3.13 For some TIs, the appropriate test equipment must be connected across the Sensing terminals instead of the Load terminals of the TI. If possible, refer to the manufacturer manual of the TI being calibrated for correct connections.

3.14 Some meters in various power supplies have no Accuracy stated in Appendix A (rating). These meters need no calibration.

**WARNING**

Turn TI power OFF prior to disconnecting or adding test equipment.

**4 CALIBRATION PROCESS:**

**NOTE**

Unless otherwise specified, verify the results of each test and take corrective action whenever the test requirement is not met, before proceeding.

**4.1 DC VOLTMETER AND AMMETER CALIBRATION: (Constant Voltage and Current)**

4.1.1 Connect test equipment as shown in Figure 1.

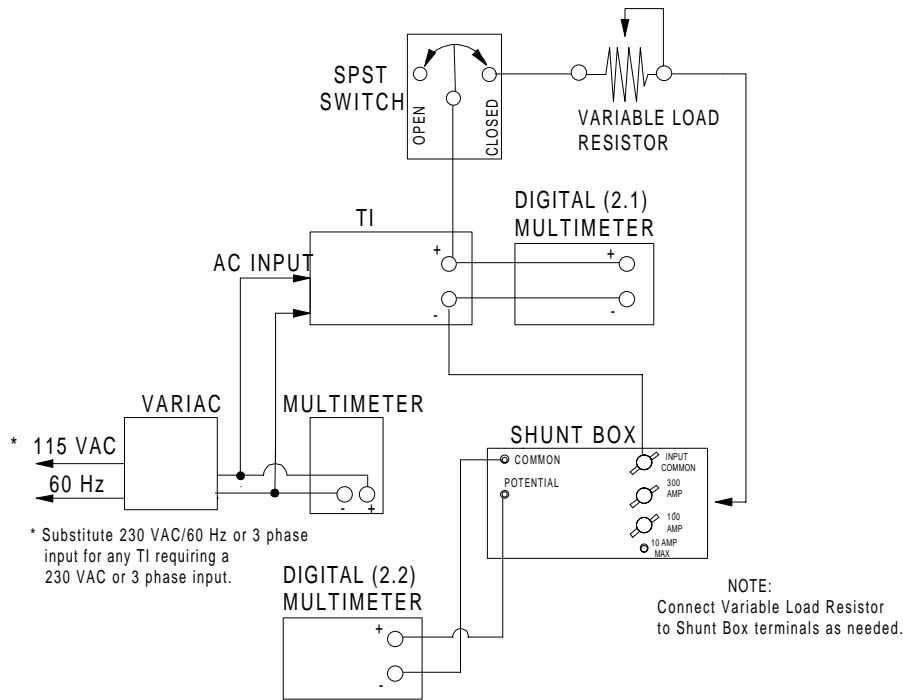

Figure 1.

4.1.2 To ensure that the TI is loaded to maximum current at maximum voltage, determine maximum Variable Load Resistor value from rating column in Appendix A and connect to Variable Load Resistor terminals. Adjust the Variable Load Resistor to ensure maximum current is drawn.

4.1.3 Set the Variac for a 115 VAC indication on the Multimeter.

4.1.4 Close the SPST switch.

4.1.5 Set Digital Multimeter (2.1 and 2.2) as needed to measure VDC.

4.1.6 Adjust TI OUTPUT VOLTAGE and/or OUTPUT CURRENT controls for rated values, then down-scale to each major cardinal point on meters or dials. If necessary, consult the commercial manual for cardinal points.

4.1.7 Record the indications on Digital Multimeter (2.1) for the TI DC Voltmeter and/or Digital Multimeter (2.2) for TI DC Ammeter.

4.1.8 Open the SPST.

4.1.9 The Digital Multimeter (2.1) recorded indications from step 4.1.7 must be within the tolerances computed from full scale rating of TI DC Voltmeter being calibrated (see step 3.10).

4.1.10 The Digital Multimeter (2.2) recorded indications from step 4.1.7 must be within the tolerances computed from full scale rating of TI DC Ammeter being calibrated (see step 3.10).

4.1.11 Set the TI output to minimum, Variac to 0 VAC. Disconnect the test setup.

## 4.2 LINE AND LOAD REGULATION CALIBRATION: (Constant Voltage)

4.2.1 Connect the equipment as shown in Figure 2.

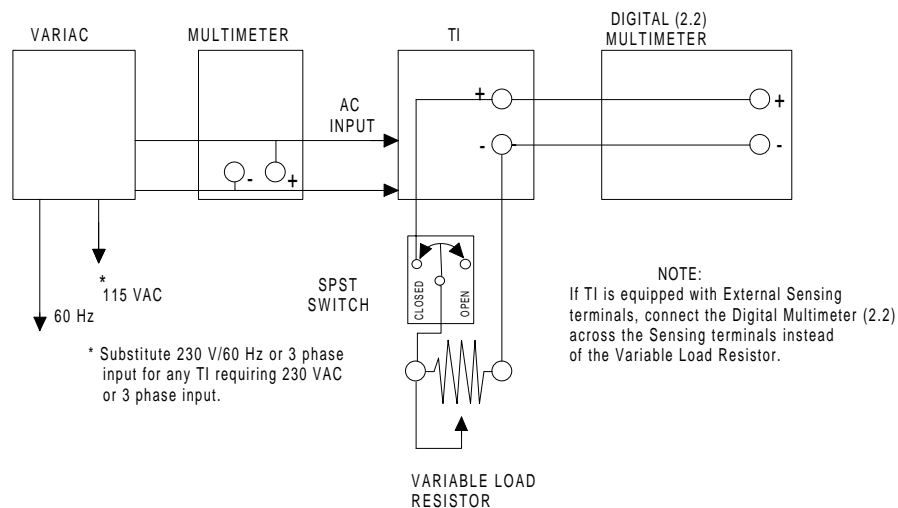

Figure 2.

4.2.2 To ensure that the TI is loaded to maximum current at maximum output voltage, determine maximum Variable Load Resistor value from rating column in Appendix A and connect to Variable Load Resistor terminals of Figure 2. Adjust the Variable Load Resistor to ensure maximum current is drawn.

- 4.2.3 If the TI is constant voltage, constant current supply, adjust the CURRENT control fully CW.
- 4.2.4 Set the Variac for a 115 VAC indication on the Multimeter.
- 4.2.5 Adjust the TI VOLTAGE control or set the output of the supply to the rated output voltage.
- 4.2.6 Close the SPST switch.
- 4.2.7 Adjust the Variac until the Multimeter indicates 105 VAC then 125 VAC for 115 V input or 207 VAC then 253 VAC for 230 V input while recording the indication of the Digital Multimeter for both line voltages.
- 4.2.8 The Digital Multimeter (2.2) change must indicate within the tolerance listed in the Regulation column of Appendix A (Line Max).
- 4.2.9 Set the Variac for a 115 VAC indication on the Multimeter.
- 4.2.10 Record the Digital Multimeter (2.2) indication.
- 4.2.11 Open the SPST switch and ensure the Digital Multimeter (2.2) change from the recorded value of step 4.2.10 indicates within the tolerance listed under the Regulation column (Load Max) of Appendix A.
- 4.2.12 Set the Variac for a 115 VAC indication on the Multimeter and close the SPST switch.

**4.3 RIPPLE AND NOISE CALIBRATION: (Constant Voltage)**

- 4.3.1 Set Digital Multimeter as needed to measure VAC.
- 4.3.2 Set TI output to full load and measure the RMS ripple of the output voltage by setting the range switch of the Digital Multimeter for the best possible ripple indication.
- 4.3.3 The Digital Multimeter (2.2) indication must not exceed the stated RMS ripple specification listed in Appendix A.
- 4.3.4 Set the TI output to OFF and disconnect the Digital Multimeter (2.2) from the TI.

**NOTE**

Only accomplish the following steps if ripple and noise specification list p-p values in Appendix A.

- 4.3.5 With the TI at full load, connect the Oscilloscope across the TI output terminals, observing polarity.
- 4.3.6 Set the output of the TI to ON and measure the p-p noise of the output voltage.
- 4.3.7 The Oscilloscope p-p noise indications must not exceed the p-p specifications listed in Appendix A.
- 4.3.8 Set the TI output to OFF and disconnect the test equipment from the TI.



#### 4.4 LINE AND LOAD REGULATION CALIBRATION: (Constant Current)

##### NOTE

In Appendix A for Constant Current Regulation where the percentage of regulation is listed in actual current, this value has been converted to percent and listed under the regular value in parenthesis. For example, at a value of Constant Current:  $\pm 250 \mu\text{A DC}$  at a full scale range of 10 ADC would be listed as  $\pm(0.0025\% \text{ FS})$ .

4.4.1 Connect the equipment as shown in Figure 3.

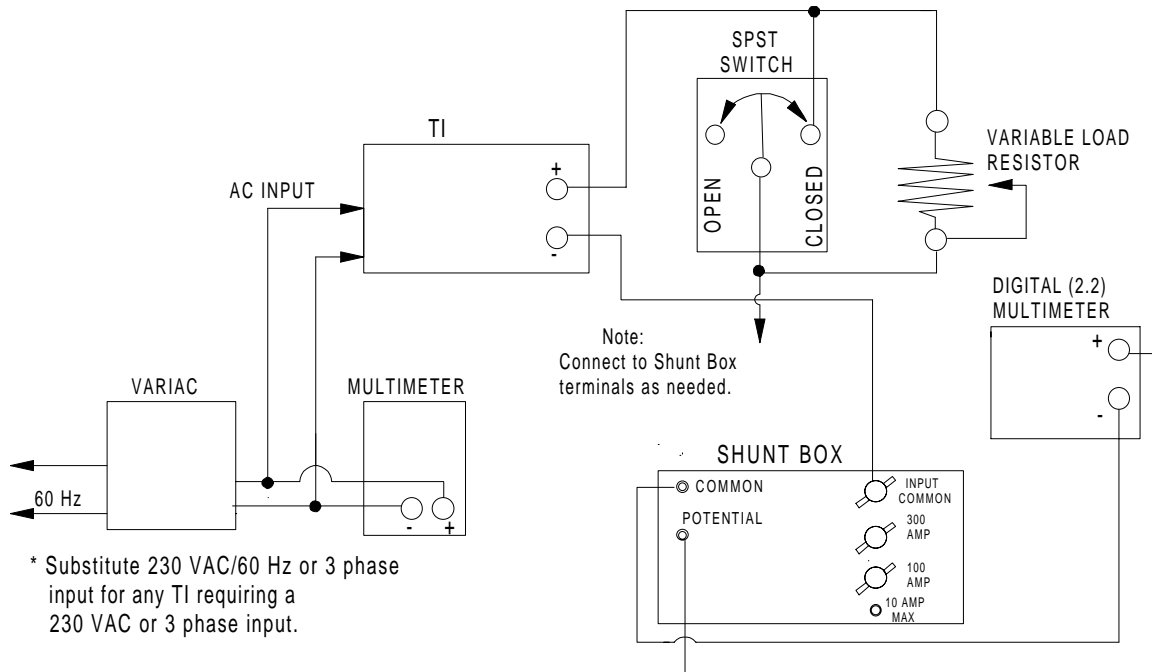

Figure 3.

4.4.2 To ensure that the TI is loaded to maximum current at maximum output voltage, determine maximum Variable Load Resistor (resistance connected across SPST shorting switch plus resistance of Shunt Box) value from rating column in Appendix A and connect to load resistor terminals of Figure 3. Adjust the Variable Load Resistor to ensure maximum current is drawn.

4.4.3 If the TI is a constant voltage, constant current supply, adjust the VOLTAGE control fully CW. If the TI is a constant current supply equipped with a VOLTAGE control, adjust for rated output voltage.

### WARNING

Do not exceed the TI rated output current in step 4.4.5.

4.4.4 For a Digital Precision power supply, lower the load resistance by about 10%. Adjust the output voltage for rated output only.

4.4.5 Adjust the TI CURRENT control or set the output of the supply to the rated output current.

4.4.6 Set the Variac for a of 115 VAC indication on the Multimeter.

- 4.4.7 Set Digital Multimeter (2.2) as needed to measure VDC, record indication and calculate the current.
- 4.4.8 Adjust the Variac until the Multimeter indicates 105 VAC then 125 VAC for 115 V input or 207 VAC then 253 VAC for 230 V input while recording the indication of the Digital Multimeter (2.2) for both line voltages and calculate the current for both line voltages.
- 4.4.9 The Digital Multimeter (2.2) change must indicate within the tolerance listed under the Regulation Line (Max) column of Appendix A.
- 4.4.10 Set the Variac for a 115 VAC indication on the Multimeter.
- 4.4.11 Close the SPST Switch.
- 4.4.12 Record the Digital Multimeter (2.2) indication and calculate the current.
- 4.4.13 Open the SPST Switch.
- 4.4.14 The difference between steps 4.4.7 and 4.4.12 must indicate within the tolerance listed under the Regulation Load (Max) column of Appendix A.
- 4.4.15 Set the TI to OFF.

**4.5 RIPPLE CALIBRATION: (Constant Current)**

- 4.5.1 Set Digital Multimeter (2.1) as needed to measure VAC.
- 4.5.2 With TI at full load, connect Digital Multimeter (2.1) or the Oscilloscope across the TI OUTPUT terminals.
- 4.5.3 Set output of TI to ON and measure the ripple content of the OUTPUT current by setting the RANGE switch of Digital Multimeter (2.1) or adjusting the SENSITIVITY controls of the Oscilloscope for best possible ripple indication.
- 4.5.4 The Digital Multimeter (2.1) or Oscilloscope indication must not exceed (the stated ripple specifications listed in Appendix A Times Load)  $Load = \frac{DC\ Volts}{DC\ Current}$
- 4.5.5 If applicable, attach a Limited Certification Label as per step 3.2, 3.5 or 3.6.
- 4.5.6 Set all POWER switches to OFF or STANDBY, disconnect and secure all equipment.

CALIBRATION PERFORMANCE TABLE

Not Required

## APPENDIX A

## DC POWER SUPPLIES

Table A-1.

## SPECIFICATIONS LISTING

Part Number	Page	Part Number	Page	Part Number	Page
AP2H.....	A-3	E3616A.....	A-8	PPS-4A.....	A-13
BHK 500-0.4M.....	A-3	E3617A.....	A-8	PPS-50-1.5.....	A-13
BPA 40 CV.....	A-3	E3620A.....	A-8	PR40-5-01-09.....	A-13
CB12A.....	A-3	E3630A.....	A-8	PR40-10A-06 SPB998.....	A-13
CPS250.....	A-3	E3631A.....	A-9	PSV-5.....	A-14
CRS36-20.....	A-3	GPR-7550D.....	A-9	PS2521G.....	A-14
DCR 20 -125A.....	A-3	GPS-3030D.....	A-28	PS280.....	A-14
DCR 20-250A.....	A-4	HCR20-13-111.....	A-9	PS281.....	A-14
DCR 40-10A.....	A-4	HCR 150-2.....	A-9	PS402.....	A-14
DCR 40-20A.....	A-4	HPD60-5.....	A-9	PVC50-0.5.....	A-15
DCR 40-25B.....	A-4	HR160-3C.....	A-10	PW18-1T.....	A-15
DCR 40-35A.....	A-4	HR20-5A.....	A-10	PW18-3A.....	A-15
DCR 40-60A.....	A-4	HWD60-3A.....	A-10	P030PX4.....	A-15
DCR 40-125A.....	A-4	IP-27.....	A-10	QRD 20-4.....	A-15
DCR 40-250A.....	A-4	KS60-10M.....	A-10	RAX28-6.2K.....	A-29
DCR 40-500A.....	A-4	LA200.....	A-10	RE40-5.....	A-16
DCR 60-90B.....	A-4	LA250.....	A-10	RS20-20B.....	A-16
DCR 60-13A.....	A-5	LCS-A-04.....	A-10	RS40-15B.....	A-16
DCR 60-25A.....	A-5	LDS-X-03.....	A-10	RS60-12B.....	A-16
DCR 60-40A.....	A-5	LE101 ( ).....	A-11	RS160-4B.....	A-16
DCR 80-5A.....	A-5	LGS-FA-5-0V-R.....	A-28	R6127.....	A-16
DCR 80-6B.....	A-5	LJS-13-5-OV.....	A-11	SBC 519.....	A-16
DCR 80-10A.....	A-5	LLS5018.....	A-11	SYR36-25-5133.....	A-16
DCR 80-18A.....	A-5	LLS-6060.....	A-29	SYR75-6.5PD.....	A-16
DCR 80-30A.....	A-5	LLS8040.....	A-11	SYR75-6.5-55139.....	A-17
DCR 150-2.5A.....	A-5	LLS9040.....	A-11	TCR 30.....	A-17
DCR 150-5A.....	A-6	LND-W-152.....	A-11	TCR 300S2.....	A-17
DCR 150-10A.....	A-6	LND-Y-152-8562.....	A-11	TCR 40S25-1D.....	A-17
DCR 150-15A.....	A-6	LNSP28.....	A-11	TCR 500T10-D-0V.....	A-17
DCR 300-1.25A.....	A-6	LNS-W-28.....	A-11	TCR 60S10-1.....	A-17
DCR 300-2.5A.....	A-6	LPD-421FM.....	A-12	TP340.....	A-18
DCR 300-5A.....	A-6	LRS53-2.....	A-12	TP343B.....	A-29
DCR 300-8A.....	A-6	LS 30-3.....	A-12	TP840.....	A-18
DCR 33-33.....	A-6	LS40-25-06.....	A-12	TW5005D.....	A-18
DCS60-50M12.....	A-6	MPS-20-1.5.....	A-12	TW6050D.....	A-19
EMS300-16.....	A-7	MSK 10-10M.....	A-12	V28PT10FH.....	A-19
ESS125-125-2.....	A-7	MSK 20-5M.....	A-12	WP-704A.....	A-19
E3610A.....	A-7	PAB160-0.4.....	A-12	WP-707B.....	A-19
E3611A.....	A-7	PAD 55-3L.....	A-12	WP718.....	A-19
E3612A.....	A-7	PD56-10.....	A-13	WP-75.....	A-19
E3614A.....	A-8	PD56-6D.....	A-13	WP-78.....	A-20
E3615A.....	A-8	PE1649.....	A-13	XTS60-1.....	A-20

**APPENDIX A (Cont.)**

DC POWER SUPPLIES

*Table A-1. (Cont.)*

SPECIFICATIONS LISTING

<b>Part Number</b>	<b>Page</b>	<b>Part Number</b>	<b>Page</b>	<b>Part Number</b>	<b>Page</b>
XTS120-0.5	A-20	6216C	A-27		
1101	A-29	6479C	A-27		
150-2-110	A-20	72-2010	A-27		
1630	A-20	72-2075	A-27		
1635	A-20	72-2080	A-28		
1635A	A-21	72-4045A	A-30		
1646	A-21	72-6615	A-28		
1651	A-21	832-210	A-28		
1660	A-21	8609	A-28		
1686	A-21	90074-2	A-28		
1711	A-22				
1730	A-22				
1735	A-22				
1743	A-22				
1760	A-22				
20300B	A-23				
20320B	A-23				
212AMK	A-23				
28PT10AF	A-23				
30-33-1-D-TC	A-23				
3005B	A-23				
3032B	A-24				
3101-3610	A-24				
3101A-3610	A-24				
3300D-4015	A-24				
3300D-6010	A-24				
3300D-7.575	A-24				
3302D	A-24				
3303D	A-24				
3306D	A-24				
3410D-4025	A-25				
3413D-1202.5	A-25				
40-125-2-D	A-25				
40S25-1	A-25				
4010	A-25				
5030	A-25				
6010D	A-25				
6023A	A-26				
6028A	A-26				
6106A	A-26				
6212C	A-27				
6214C	A-27				

**APPENDIX A (Cont.)**

<b>Model, P/N or Type</b>	<b>Mfg</b>	<b>Rating</b>	<b>Line (Max)</b>	<b>Regulation</b>	<b>Load (Max)</b>	<b>Ripple</b>
AP-2H	Berkeley Nucleonics	±24 VDC, 0 to 1 ADC; ±12 VDC, 0 to 0.5 ADC	CV Better than 0.1%; Voltage Variation ±12%	CV Better than 0.1%; no load to full load	CV Less than 3 mV p-p when observed with a 50 MHz bandwidth oscilloscope	
BHK 500-0.4M	Kepeco	0 to 500 VDC, 0.4 ADC; Mtr Acc: ±2% FS	CV <0.005% or 1 mV DC *1; CC <100 µA DC	CV <0.01% or 1 mV DC *1; CC <100 µA DC	CV <1 mV rms; CC <100 µA rms	
BPA 40 CV	Power Mount	0 to 40 VDC, 0 to 0.75 ADC	CV 0.01% + 1 mV DC	CV 0.01% + 1 mV DC	CV Less than 500 µV rms	
CB12A *2	Tinker	6 to 32 VDC, 0 to 5 ADC; Mtr Acc: ±0.25 VDC, ±0.25 ADC	N/A	N/A	N/A	
CPS250	Tektronix	5 VDC, 2 ADC; Dual, 0 to 20 VDC, 500 mA DC; Mtr Acc: ±2.5% FS	CV 5 V, ±10 mV DC; CV 0 to 20 VDC, 0.01% + 3 mV DC; CC 0.2% + 3 mA DC	CV 5 VDC, ±0.1% + 5 mV DC; CV 0 to 20 VDC, 0.01% + 3 mV DC; CC 0.2% + 6 mA DC	CV 5 VDC, 2 mV rms; CV 0 to 20 VDC, 2 mV rms; CC 3 mA rms	
CRS36-20	NJE	0 to 36 VDC, 0 to 20 ADC; Mtr Acc: ±2% FS	CV 0.02% or 1 mV DC *1	CV 0.02% or 2 mV DC *1	CV 1 mV rms	
DCR 20-125A	Sorensen/ Raytheon	0 to 20 VDC, 0 to 125 ADC	CV ±0.075% or ±8 mV DC *1; CC ±125 mA DC (19 to 0 VDC)	CV ±0.075% or ±8 mV DC *1; CC ±125 mA DC (19 to 0 VDC)	CV 0.4% + 20 mV rms CC 0.5% IO	

See footnotes at end of Table.

## APPENDIX A (Cont.)

Model, P/N or Type	Mfg	Rating	Line (Max)	Regulation	Load (Max)	Ripple
DCR 20-250A	Sorensen/ Raytheon	0 to 20 VDC, 0 to 250 ADC	CV $\pm 0.10\%$ or $\pm 8$ mV DC <sup>*1</sup> ; CC $\pm 500$ mA DC (19 to 0 VDC)	CV $\pm 0.10\%$ or $\pm 8$ mV DC <sup>*1</sup> ; CC $\pm 500$ mA DC, (19 to 0 VDC)	CV $\pm 0.10\%$ or $\pm 8$ mV DC <sup>*1</sup> ; CC $\pm 500$ mA DC, (19 to 0 VDC)	CV 0.8% + 60 mV rms or 160 mV rms <sup>*3</sup> ; CC 0.5% IO
DCR 40-10A	Sorensen/ Raytheon	0 to 40 VDC, 0 to 10 ADC	CV $\pm 0.075\%$ or $\pm 15$ mV DC <sup>*1</sup> ; CC $\pm 20$ mA DC (38 to 0 VDC)	CV $\pm 0.075\%$ or $\pm 15$ mV DC <sup>*1</sup> ; CC $\pm 20$ mA DC (38 to 0 VDC)	CV $\pm 0.075\%$ or $\pm 15$ mV DC <sup>*1</sup> ; CC $\pm 20$ mA DC (38 to 0 VDC)	CV 0.4% + 40 mV rms; CC 0.5% IO
DCR 40-20A	Sorensen/ Raytheon	0 to 40 VDC, 0 to 20 ADC	CV $\pm 0.075\%$ or $\pm 15$ mV DC <sup>*1</sup> ; CC $\pm 25$ mA DC (38 to 0 VDC)	CV $\pm 0.075\%$ or $\pm 15$ mV DC <sup>*1</sup> ; CC $\pm 25$ mA DC (38 to 0 VDC)	CV $\pm 0.075\%$ or $\pm 15$ mV DC <sup>*1</sup> ; CC $\pm 25$ mA DC (38 to 0 VDC)	CV 0.4% + 40 mV rms; CC 0.5% IO
DCR 40-25B	Sorensen/ Raytheon	0 to 40 VDC, 0 to 25 ADC	CV 0.03%; CC 0.25%	CV 0.03%; CC 0.25%	CV 0.03%; CC 0.25%	CV 0.1% + 90 mV rms; CC 0.15% + 56 mA rms IO
DCR 40-35A	Sorensen/ Raytheon	0 to 40 VDC, 0 to 35 ADC	CV $\pm 0.075\%$ or $\pm 15$ mV DC <sup>*1</sup> ; CC $\pm 35$ mA DC (38 to 0 VDC)	CV $\pm 0.075\%$ or $\pm 15$ mV DC <sup>*1</sup> ; CC $\pm 35$ mA DC (38 to 0 VDC)	CV $\pm 0.075\%$ or $\pm 15$ mV DC <sup>*1</sup> ; CC $\pm 35$ mA DC (38 to 0 VDC)	CV 0.04% + 40 mV rms; CC 0.5% IO
DCR 40-60A	Sorensen/ Raytheon	0 to 40 VDC, 0 to 60 ADC	CV $\pm 0.075\%$ or $\pm 15$ mV DC <sup>*1</sup> ; CC $\pm 60$ mA DC (38 to 0 VDC)	CV $\pm 0.075\%$ or $\pm 15$ mV DC <sup>*1</sup> ; CC $\pm 60$ mA DC (38 to 0 VDC)	CV $\pm 0.075\%$ or $\pm 15$ mV DC <sup>*1</sup> ; CC $\pm 60$ mA DC (38 to 0 VDC)	CV 0.04% + 40 mV rms; CC 0.5% IO
DCR 40-125A	Sorensen/ Raytheon	0 to 40 VDC, 0 to 125 ADC	CV $\pm 0.10\%$ or $\pm 15$ mV DC <sup>*1</sup> ; CC $\pm 250$ mA DC (38 to 0 VDC)	CV $\pm 0.10\%$ or $\pm 15$ mV DC <sup>*1</sup> ; CC $\pm 250$ mA DC (38 to 0 VDC)	CV $\pm 0.10\%$ or $\pm 15$ mV DC <sup>*1</sup> ; CC $\pm 250$ mA DC (38 to 0 VDC)	CV 0.4% + 60 mV rms or 150 mV rms <sup>*3</sup> ; CC 0.5% IO
DCR 40-250A	Sorensen/ Raytheon	0 to 40 VDC, 0 to 250 ADC	CV $\pm 0.10\%$ or $\pm 15$ mV DC <sup>*1</sup> ; CC $\pm 500$ mA DC (38 to 0 VDC)	CV $\pm 0.10\%$ or $\pm 15$ mV DC <sup>*1</sup> ; CC $\pm 500$ mA DC (38 to 0 VDC)	CV $\pm 0.10\%$ or $\pm 15$ mV DC <sup>*1</sup> ; CC $\pm 500$ mA DC (38 to 0 VDC)	CV 0.4% + 60 mV rms or 160 mV <sup>*3</sup> ; CC 0.5% IO
DCR 40-500A	Sorensen/ Raytheon	0 to 40 VDC, 0 to 500 ADC	CV $\pm 0.10\%$ or $\pm 15$ mV DC <sup>*1</sup> ; CC $\pm 1000$ mA DC (38 to 0 VDC)	CV $\pm 0.10\%$ or $\pm 15$ mV DC <sup>*1</sup> ; CC $\pm 500$ mA DC (38 to 0 VDC)	CV $\pm 0.10\%$ or $\pm 15$ mV DC <sup>*1</sup> ; CC $\pm 500$ mA DC (38 to 0 VDC)	CV 0.4% + 60 mV DC or 160 mV DC <sup>*3</sup> ; CC 0.5% IO
DCR 60-9B	Sorensen/ Raytheon	0 to 60 VDC, 0 to 9 ADC	CV 18 mV DC; CC 22.5 mA DC	CV 18 mV DC; CC 22.5 mA DC	CV 18 mV DC; CC 22.5 mA DC	CV 125 mV rms

See footnotes at end of Table.

APPENDIX A (Cont.)

Model, P/N or Type	Mfg	Rating	Line (Max)	Regulation	Load (Max)	Ripple
DCR 60-13A	Sorensen/ Raytheon	0 to 60 VDC,	CV $\pm 0.075\%$ or $\pm 15$ mV DC <sup>*1</sup> ;	CV $\pm 0.075\%$ or $\pm 15$ mV DC <sup>*1</sup> ;	CV $\pm 0.075\%$ or $\pm 15$ mV DC <sup>*1</sup> ;	CV 0.4% + 60 mV rms;
		0 to 13 ADC	CC $\pm 20$ mA DC (57 to 0 VDC)	CC $\pm 20$ mA DC (57 to 0 VDC)	CC $\pm 20$ mA DC (57 to 0 VDC)	CC 0.5% IO
DCR 60-25A	Sorensen/ Raytheon	0 to 60 VDC,	CV $\pm 0.075\%$ or $\pm 15$ mV DC <sup>*1</sup>	CV $\pm 0.075\%$ or $\pm 15$ mV DC <sup>*1</sup> ;	CV $\pm 0.075\%$ or $\pm 15$ mV DC <sup>*1</sup> ;	CV 0.4% + 60 mV rms;
		0 to 25 ADC	CC $\pm 25$ mA DC (57 to 0 VDC)	CC $\pm 25$ mA DC (57 to 0 VDC)	CC $\pm 25$ mA DC (57 to 0 VDC)	CC 0.5% IO
DCR 60-40A	Sorensen/ Raytheon	0 to 60 VDC,	CV $\pm 0.075\%$ or $\pm 15$ mV DC <sup>*1</sup> ;	CV $\pm 0.075\%$ or $\pm 15$ mV DC <sup>*1</sup> ;	CV $\pm 0.075\%$ or $\pm 15$ mV DC <sup>*1</sup> ;	CV 0.4% + 60 mV rms;
		0 to 40 ADC	CC $\pm 40$ mA DC (57 to 0 VDC)	CC $\pm 40$ mA DC (57 to 0 VDC)	CC $\pm 40$ mA DC (57 to 0 VDC)	CC 0.5% IO
DCR 80-5A	Sorensen/ Raytheon	0 to 80 VDC,	CV $\pm 0.075\%$ or $\pm 20$ mV DC <sup>*1</sup> ;	CV $\pm 0.075\%$ or $\pm 20$ mV DC <sup>*1</sup> ;	CV $\pm 0.075\%$ or $\pm 20$ mV DC <sup>*1</sup> ;	CV 0.4% + 80 mV rms;
		0 to 5 ADC	CC $\pm 15$ mA DC (75 to 0 VDC)	CC $\pm 15$ mA DC (75 to 0 VDC)	CC $\pm 15$ mA DC (75 to 0 VDC)	CC 0.5% IO
DCR 80-6B	Sorensen/ Raytheon	0 to 80 VDC,	CV 0.03%;	CV 0.03%;	CV 0.03%;	CV 150 mV rms;
		0 to 6 ADC	CC 0.25% (0 to 95% compliance-voltage change)	CC 0.25% (0 to 95% compliance-voltage change)	CC 0.25% (0 to 95% compliance-voltage change)	CC 12 mA rms
DCR 80-10A	Sorensen/ Raytheon	0 to 80 VDC,	CV $\pm 0.075\%$ or $\pm 20$ mV DC <sup>*1</sup> ;	CV $\pm 0.075\%$ or $\pm 20$ mV DC <sup>*1</sup> ;	CV $\pm 0.075\%$ or $\pm 20$ mV DC <sup>*1</sup> ;	CV 0.4% + 80 mV rms;
		0 to 10 ADC	CC $\pm 20$ mA DC (75 to 0 VDC)	CC $\pm 20$ mA DC (75 to 0 VDC)	CC $\pm 20$ mA DC (75 to 0 VDC)	CC 0.5% IO
DCR 80-18A	Sorensen/ Raytheon	0 to 80 VDC,	CV $\pm 0.075\%$ or $\pm 20$ mV DC <sup>*1</sup> ;	CV $\pm 0.075\%$ or $\pm 20$ mV DC <sup>*1</sup> ;	CV $\pm 0.075\%$ or $\pm 20$ mV DC <sup>*1</sup> ;	CV 0.4% + 80 mV rms;
		0 to 18 ADC	CC $\pm 25$ mA DC (75 to 0 VDC)	CC $\pm 25$ mA DC (75 to 0 VDC)	CC $\pm 25$ mA DC (75 to 0 VDC)	CC 0.5% IO
DCR 80-30A	Sorensen/ Raytheon	0 to 80 VDC,	CV $\pm 0.075\%$ or $\pm 20$ mV DC <sup>*1</sup> ;	CV $\pm 0.075\%$ or $\pm 20$ mV DC <sup>*1</sup> ;	CV $\pm 0.075\%$ or $\pm 20$ mV DC <sup>*1</sup> ;	CV 0.4% + 80 mV rms;
		0 to 30 ADC	CC $\pm 30$ mA DC (75 to 0 VDC)	CC $\pm 30$ mA DC (75 to 0 VDC)	CC $\pm 30$ mA DC (75 to 0 VDC)	CC 0.5% IO
DCR 150-2.5A	Sorensen/ Raytheon	0 to 150 VDC,	CV $\pm 0.075\%$ or $\pm 30$ mV DC <sup>*1</sup> ;	CV $\pm 0.075\%$ or $\pm 30$ mV DC <sup>*1</sup> ;	CV $\pm 0.075\%$ or $\pm 30$ mV DC <sup>*1</sup> ;	CV 0.4% + 150 mV rms;
		0 to 2.5 ADC	CC $\pm 15$ mA DC (140 to 0 VDC)	CC $\pm 15$ mA DC (140 to 0 VDC)	CC $\pm 15$ mA DC (140 to 0 VDC)	CC 0.5% IO

See footnotes at end of Table.

## APPENDIX A (Cont.)

Model, P/N or Type	Mfg	Rating	Line (Max)	Regulation	Load (Max)	Ripple
DCR 150-5A	Sorensen/ Raytheon	0 to 150 VDC, 0 to 5 ADC	CV $\pm 0.075\%$ or $\pm 30$ mV DC * <sup>1</sup> ; CC $\pm 15$ mA DC (140 to 0 VDC)	CV $\pm 0.075\%$ or $\pm 30$ mV DC * <sup>1</sup> ; CC $\pm 15$ mA DC (140 to 0 VDC)	CV $\pm 0.075\%$ or $\pm 30$ mV DC * <sup>1</sup> ; CC $\pm 15$ mA DC (140 to 0 VDC)	CV 0.4% + 150 mV rms; CC 0.5% IO
DCR 150-10A	Sorensen/ Raytheon	0 to 150 VDC, 0 to 10 ADC	CV $\pm 0.075\%$ or $\pm 30$ mV DC * <sup>1</sup> ; CC $\pm 20$ mA DC (140 to 0 VDC)	CV $\pm 0.075\%$ or $\pm 30$ mV DC * <sup>1</sup> ; CC $\pm 20$ mA DC (140 to 0 VDC)	CV $\pm 0.075\%$ or $\pm 30$ mV DC * <sup>1</sup> ; CC $\pm 20$ mA DC (140 to 0 VDC)	CV 0.4% + 150 mV rms; CC 0.5% IO
DCR 150-15A	Sorensen/ Raytheon	0 to 150 VDC, 0 to 15 ADC	CV $\pm 0.075\%$ or $\pm 30$ mV DC * <sup>1</sup> ; CC $\pm 25$ mA DC (140 to 0 VDC)	CV $\pm 0.075\%$ or $\pm 30$ mV DC * <sup>1</sup> ; CC $\pm 25$ mA DC (140 to 0 VDC)	CV $\pm 0.075\%$ or $\pm 30$ mV DC * <sup>1</sup> ; CC $\pm 25$ mA DC (140 to 0 VDC)	CV 0.4% + 150 mV rms; CC 0.5% IO
DCR 300-1.25 A	Sorensen/ Raytheon	0 to 300 VDC, 0 to 1.25 ADC	CV $\pm 0.075\%$ or $\pm 60$ mV DC * <sup>1</sup> ; CC $\pm 15$ mA DC (280 to 0 VDC)	CV $\pm 0.075\%$ or $\pm 60$ mV DC * <sup>1</sup> ; CC $\pm 15$ mA DC (280 to 0 VDC)	CV $\pm 0.075\%$ or $\pm 60$ mV DC * <sup>1</sup> ; CC $\pm 15$ mA DC (280 to 0 VDC)	CV 0.4% + 300 mV rms; CC 0.5% IO
DCR 300-2.5A	Sorensen/ Raytheon	0 to 300 VDC, 0 to 2.5 ADC	CV $\pm 0.075\%$ or $\pm 60$ mV DC * <sup>1</sup> ; CC $\pm 15$ mA DC (280 to 0 VDC)	CV $\pm 0.075\%$ or $\pm 60$ mV DC * <sup>1</sup> ; CC $\pm 15$ mA DC (280 to 0 VDC)	CV $\pm 0.075\%$ or $\pm 60$ mV DC * <sup>1</sup> ; CC $\pm 15$ mA DC (280 to 0 VDC)	CV 0.4% + 300 mV rms; CC 0.5% IO
DCR 300-5A	Sorensen/ Raytheon	0 to 300 VDC, 0 to 5 ADC	CV $\pm 0.075\%$ or $\pm 60$ mV DC * <sup>1</sup> ; CC $\pm 15$ mA DC (280 to 0 VDC)	CV $\pm 0.075\%$ or $\pm 60$ mV DC * <sup>1</sup> ; CC $\pm 15$ mA DC (280 to 0 VDC)	CV $\pm 0.075\%$ or $\pm 60$ mV DC * <sup>1</sup> ; CC $\pm 15$ mA DC (280 to 0 VDC)	CV 0.4% + 300 mV rms; CC 0.5% IO
DCR 300-8A	Sorensen/ Raytheon	0 to 300 VDC, 0 to 8 ADC	CV $\pm 0.075\%$ or $\pm 60$ mV DC * <sup>1</sup> ; CC $\pm 20$ mA DC (280 to 0 VDC)	CV $\pm 0.075\%$ or $\pm 60$ mV DC * <sup>1</sup> ; CC $\pm 20$ mA DC (280 to 0 VDC)	CV $\pm 0.075\%$ or $\pm 60$ mV DC * <sup>1</sup> ; CC $\pm 20$ mA DC (280 to 0 VDC)	CV 0.4% + 300 mV rms; CC 0.5% IO
DCS 33-33	Sorensen	0 to 33 VDC, 0 to 33 ADC; Mfr Acc: Voltage $\pm 0.43$ VDC; Current $\pm 0.43$ ADC	CV 33 mV DC; CC 33 mA DC	CV 33 mV DC; CC 33 mA DC	CV 33 mV DC; CC 33 mA DC	CV 10 mV rms, 100 mV p-p (20 Hz to 20 MHz)
DCS60- 50M12	Sorensen/ Raytheon	0 to 60 VDC, 0 to 50 ADC	CV 60 mV DC; CC 50 mA DC	CV 60 mV DC; CC 50 mA DC	CV 60 mV DC; CC 50 mA DC	CV 20 mV rms; 100 mV p-p

See footnotes at end of Table.



APPENDIX A (Cont.)

Model, P/N or Type	Mfg	Rating	Line (Max)	Regulation	Load (Max)	Ripple
EMS300-16	Electronic Measurements	300 VDC, 16 ADC	CV 0.1%; CC 0.1%		CV 0.1%; CC 0.1%	CV 40 mV rms; 200 mV p-p
ESS125-125-2	Lambda	0 to 125 VDC, 0 to 125 ADC	CV <0.1%; CC <0.1%		CV <0.1%; CC <0.1%	CV 120 mV p-p
E3610A	Hewlett-Packard	0 to 8 VDC, 0 to 3 ADC or 0 to 15 VDC, 0 to 2 ADC; Mtr Acc: $\pm(0.5\% \text{ rdg} + 2 \text{ dgts})$	CV 0.01% + 2 mV DC; CC 0.01% + 1 mA DC	CV 0.01% + 2 mV DC; CC 0.01% + 1 mA DC	CV 0.01% + 2 mV DC; CC 0.01% + 1 mA DC	CV 200 $\mu$ V rms and 2 mV p-p (10 Hz to 10 MHz); CC 200 $\mu$ A rms and 1 mA p-p (10 Hz to 10 MHz)
E3611A	Hewlett-Packard	0 to 20 V, 0 to 1.5 ADC or 0 to 35 VDC, 0 to 0.85 ADC; Mtr Acc: $\pm(0.5\% \text{ rdg} + 2 \text{ dgts})$	CV 0.01% + 2 mV DC; CC 0.01% + 1 mA DC	CV 0.01% + 2 mV DC; CC 0.01% + 1 mA DC	CV 0.01% + 2 mV DC; CC 0.01% + 1 mA DC	CV 200 $\mu$ V rms and 2 mV p-p (10 Hz to 10 MHz); CC 200 $\mu$ A rms and 1 mA p-p (10 Hz to 10 MHz)
E3612A	Hewlett-Packard	0 to 60 VDC, 0 to 0.5 ADC or 0 to 120 VDC, 0 to 0.25 ADC; Mtr Acc: $\pm(0.5\% \text{ rdg} + 2 \text{ dgts})$	CV <0.01% + 2 mV DC; CC <0.01% + 1 mA DC	CV <0.01% + 2 mV DC; CC <0.01% + 1 mA DC	CV <0.01% + 2 mV DC; CC <0.01% + 1 mA DC	CV <200 $\mu$ V rms and 2 mV p-p (10 Hz to 10 MHz); CC <200 $\mu$ A rms and <1 mA p-p (10 Hz to 10 MHz)

## APPENDIX A (Cont.)

Model, P/N or Type	Mfg	Rating	Line (Max)	Regulation	Load (Max)	Ripple
E3614A	Hewlett- Packard	0 to 8 VDC, 0 to 6 ADC; Mtr Acc: $\pm(0.5\%$ rdg + 2 dgts)	CV 0.01% + 2 mV DC; CC 0.01% + 250 $\mu$ A DC	CV 0.01% + 2 mV DC; CC 0.01% + 250 mA DC	CV 0.01% + 2 mV DC; CC 0.01% + 250 mA DC	CV 200 mV rms and 1 mV p-p, (20 Hz to 20 MHz); CC 5 mA rms
E3615A	Hewlett- Packard	0 to 20 VDC, 0 to 3 ADC; Mtr Acc: $\pm(0.5\%$ rdg + 2 dgts)	CV 0.01% + 2 mV DC; CC 0.01% + 250 $\mu$ A DC	CV 0.01% + 2 mV DC; CC 0.01% + 250 $\mu$ A DC	CV 0.01% + 2 mV DC; CC 0.01% + 250 $\mu$ A DC	CV 200 $\mu$ V rms and 1 mV p-p (20 Hz to 20 MHz); CC 2 mA rms
E3616A	Hewlett- Packard	0 to 35 VDC, 0 to 1.7 ADC; Mtr Acc: $\pm(0.5\%$ rdg + 2 dgts)	CV 0.01% + 2 mV DC; CC 0.01% + 250 $\mu$ A DC	CV 0.01% + 2 mV DC; CC 0.01% + 250 $\mu$ A DC	CV 0.01% + 2 mV DC; CC 0.01% + 250 $\mu$ A DC	CV 200 $\mu$ V rms and 1 mV p-p (20 Hz to 20 MHz); CC 500 $\mu$ A rms
E3617A	Hewlett- Packard	0 to 60 VDC, 0 to 1 ADC; Mtr Acc: $\pm(0.5\%$ rdg + 2 dgts)	CV <0.01% + 2 mV DC; CC <0.01% + 250 $\mu$ A DC	CV <0.01% + 2 mV DC; CC <0.01% + 250 $\mu$ A DC	CV <0.01% + 2 mV DC; CC <0.01% + 250 $\mu$ A DC	CV <200 $\mu$ V rms and 1 mV p-p (20 Hz to 20 MHz); CC <500 $\mu$ A rms
E3620A	Hewlett- Packard	V1 + V2 outputs (Both) 0 to 25 VDC, 1 ADC; Mtr Acc: $\pm(0.5\%$ rdg + 2 dgts)	CV 0.01% + 2 mV DC	CV 0.01% + 2 mV DC	CV 0.01% + 2 mV DC	CV 0.35 mV rms (20 Hz to 20 MHz)
E3630A	Hewlett- Packard	0 to 6 VDC, 2.5 ADC; 0 to 20 VDC, 0.5 ADC; 0 to -20 VDC, 0.5 ADC	CV 0.01% + 2 mV DC	CV 0.01% + 2 mV DC	CV 0.01% + 2 mV DC	CV 350 $\mu$ V rms, 1.5 mV p-p

APPENDIX A (Cont.)

Model, P/N or Type	Mfg	Rating	Line (Max)	Regulation	Load (Max)	Ripple
E3631A	Hewlett-Packard	0 to 6 VDC, 5 ADC; Mtr Acc: V, $\pm(0.1\% + 5 \text{ mV DC})$ ; C, $\pm(0.2\% + 10 \text{ mA DC})$	CV 0.01% + 2 mV DC; CC 0.01% + 250 $\mu\text{A DC}$	CV 0.01% + 2 mV DC; CC 0.01% + 250 $\mu\text{A DC}$	CV 0.01% + 2 mV DC; CC 0.01% + 250 $\mu\text{A DC}$	CV 350 $\mu\text{V DC}$ , 2 mV p-p; CC 2 mA rms
GPR-7550D	Goodwill	0 to +25 VDC, 1 ADC; 0 to -25 VDC, 1 ADC; Mtr Acc: V, $\pm(0.05\% + 20 \text{ mV DC})$ ; C $\pm(0.15\% + 4 \text{ mA DC})$	CV 0.01% + 2 mV DC; CC 0.01% + 250 $\mu\text{A DC}$	CV 0.01% + 2 mV DC; CC 0.01% + 250 $\mu\text{A DC}$	CV 0.01% + 2 mV DC; CC 0.01% + 250 $\mu\text{A DC}$	CV 350 $\mu\text{V DC}$ , 2 mV p-p; CC 500 $\mu\text{A rms}$
HCR 20-13-111	Electronic Measurements	0 to 75 VDC, 0 to 5 ADC; Mtr Acc: $\pm(0.5\% \text{ rdg} + 2 \text{ dgts})$	CV 0.01% + 3 mV DC; CC 0.2% + 3 mA DC	CV 0.01% + 3 mV DC; CC 0.2% + 3 mA DC	CV 0.01% + 5 mV DC; CC 0.2% + 5 mA DC	CV 1 mV rms; CC 5 mA rms
HCR 150-2	Electronic Measurements	0 to 300 VDC, 0 to 0.9 ADC	CV 0.1%; CC 0.25%	CV 0.1%; CC 0.25%	CV 0.25%; CC 0.1%	CV 500 mV rms; CC 2.5 mA rms
HPD60-5	Sorenson	0 to 150 VDC, 0 to 2 ADC	CV $\pm 0.1\%$	CV $\pm 0.1\%$	CV $\pm 0.1\%$	CV 300 mV rms; CC 3 mA rms
		0 to 60 VDC, 0 to 5 ADC; Mtr Acc: 0.7 VDC, 0.06 ADC	CV 8 mV DC; CC 1.5 mA DC	CV 8 mV DC; CC 1.5 mA DC	CV 8 mV DC; CC 1.5 mA DC	CV 5 mV rms, 100 mV p-p

## APPENDIX A (Cont.)

Model, P/N or Type	Mfg	Rating	Line (Max)	Regulation	Load (Max)	Ripple
HR160-3C	Trygon	0 to 160 VDC, 0 to 5 ADC	CV 0.01% or 2 mV DC * <sup>1</sup> ; CC 0.01% or 2 mA DC * <sup>1</sup>	CV 0.01% or 3 mV DC * <sup>1</sup> ; CC 0.01% or 3 mA DC * <sup>1</sup>	CV <0.5 mV rms	
HR20-5A	Trygon	0 to 20 VDC, 0 to 5 ADC	CV 0.01% or 2 mV DC * <sup>1</sup> ; CC 0.01% or 2 mA DC * <sup>1</sup>	CV 0.01% or 3 mV DC * <sup>1</sup> ; CC 0.01% or 3 mA DC * <sup>1</sup>	CV <0.5 mV rms	
HWD60-3A	Mid-Eastern Industries Inc.	0 to 60 VDC, 0 to 3 ADC	CV 0.01%; CC 0.5% Full Compliance	CV 0.01% or 4 mV DC * <sup>1</sup> ; CC 0.5% Full Compliance	CV 1 mV rms; CC 6 mA rms	
IP-27	Heathkit Inc.	50 VDC, 1.5 ADC	CV 0.05% with 5% line volts change. 105 to 125	CV less than ±15 mV DC from no-load to full-load	CV 250 μV rms maximum	
KS60-10M	Kepco	60 VDC, 10 ADC; Mfr Acc: ±2% FS	CV 0.005%; CC 0.01% or 1 mA DC * <sup>1</sup>	CV 0.01% or mV DC * <sup>1</sup> ; CC 0.01 A to 0.01%	CV 51 mV rms	
LA200	Lambda	1.0 to 16.5 VDC, 0 to 4 ADC	CV 20 mV DC, Variations 85 to 132 VAC	CV 20 mV DC	CV 60 mV p-p	
LA250	Lambda	10 to 32.5 VDC, 0 to 2 ADC	CV 40 mV DC Variations 85 to 132 VAC	CV 40 mV DC	CV 80 mV p-p	
LCS-A-04	Lambda	0 to 60 VDC, 0.37 ADC	CV ±0.01 + 1 mV DC	CV ±0.01 + 1 mV DC	CV 250 μV rms, 1 mV p-p	
LDS-X-03	Lambda	0 to 32 VDC, 0 to 1.25 ADC, w/cover installed	CV 0.005% + 0.5 mV DC input variation 105 to 127 VAC	CV 0.005% + 0.5 mV DC	CV 150 μV rms, 1 mV p-p	

See footnotes at end of Table.

APPENDIX A (Cont.)

Model, P/N or Type	Mfg	Rating	Line (Max)	Regulation	Load (Max)	Ripple
LE101 ( )	Lambda	0 to 36 VDC, 0 to 5 ADC	CV 0.05% or 8 mV DC *1 input variation 105 to 135 VAC; CC 0.2% or 15 mA DC *1 input variation 105 to 135 VAC	CV 0.05% or 8 mV DC *1; CC 0.2% or 15 mA DC *1	CV <0.5 mV rms; CC 10 mA rms	
LJS-13-5-OV	Lambda	5 VDC, 5 ADC	CV 0.4 VDC	CV 0.4 VDC	CV 10 mV rms	
LLS5018	Lambda	0 to 18 VDC, 0 to 4.5 ADC	CV 0.05%; CC 0.03%	CV 0.05%; CC 0.03%	CV 5 mV rms, 35 mV p-p; CC 1.0%	
LLS8040	Lambda	0 to 40 VDC, 0 to 10 ADC	CV 0.05%; CC 0.3%	CV 0.05%; CC 0.3%	CV 10 mV rms, 75 mV p-p; CC 1.0%	
LLS9040	Lambda	0 to 40 VDC; 0 to 10 ADC	CV 0.05%; CC 0.3%	CV 0.05%; CC 0.3%	CV 10 mV, 75 mV p-p; CC 1.0%	
LND-W-152	Lambda	±12 VDC, 3.1 ADC; ±15 VDC, 3.3 ADC	CV 0.1% (105 to 127 VAC) (210 to 254 VAC)	CV 0.1%	CV 1.5 mV rms, 5 mV p-p	
LND-Y-152-8562	Lambda	0 to 15 VDC; 0 to 1.4 ADC	CV 0.1% CC 0.1%	CV 0.1% CC 0.1%	CV 1.5 mV rms, 5 mV p-p	
LNSP28	Lambda	28 VDC ±5%, 8.0 ADC	CV 0.1%, input line voltage 105 to 127 VAC	CV 0.1%	CV 1.5 mV rms maximum	
LNS-W-28	Lambda	0 to 28 VDC; 0 to 4.7 ADC	CV 0.1%; CC 0.1%	CV 0.1%; CC 0.1%	CV 1.5 mV rms, 5 mV p-p	

See footnotes at end of Table.

## APPENDIX A (Cont.)

Model, P/N or Type	Mfg	Rating	Line (Max)	Regulation	Load (Max)	Ripple
LPD-421FM	Lambda Electronics	0 to 20 VDC; 0 to 1.7ADC	CV 0.01% + 1 mV DC; CC 5 mA DC	CV 0.01% + 1 mV DC; CC 5 mA DC	CV 0.01% + 1 mV DC; CC 5 mA DC	CV Less than 500 $\mu$ V rms positive or negative ground
LRS53-2	Lambda	2 VDC $\pm$ 5%, 25 ADC	CV $\pm$ 0.1%; CC $\pm$ 0.1%	CV $\pm$ 0.1%; CC $\pm$ 0.1%	CV $\pm$ 0.1%; CC $\pm$ 0.1%	CV 10 mV rms; 35 mV p-p
LS 30-3	Sorensen	0 to 30 VDC, 0 to 3 ADC; Mtr Acc: $\pm$ (0.5% of rdg + 2 dgts)	CV $\leq$ 0.01% + 3 mV DC; CC $\leq$ 0.2% + 3 mA DC	CV $\leq$ 0.01% + 3 mV DC; CC $\leq$ 0.2% + 3 mA DC	CV $\leq$ 0.01% + 3 mV DC; CC $\leq$ 0.2% + 3 mA DC	CV $\leq$ 0.5 mV rms; CC $\leq$ 3 mA rms
LS40-25-06	Mid- Eastern Industries Inc.	0 to 40 VDC, 0 to 25 ADC	CV 0.005%; CC 0.01%	CV 0.005%; CC 0.01%	CV 0.01%; CC 0.1%	CV 500 $\mu$ V rms
MPS-20-1.5	Electro- dyne Systems	0 to 20 VDC, 0 to 1.5 ADC; 0 to 35 VDC, 0.85 ADC; Mtr Acc: $\pm$ 3% FS	CV 0.01% + 4 mV DC; CC 0.04% + 250 $\mu$ A DC	CV 0.01% + 4 mV DC; CC 0.04% + 250 $\mu$ A DC	CV 0.01% + 4 mV DC; CC 0.2% + 250 $\mu$ A DC	CV 200 $\mu$ V rms, 1 mV p-p; CC 500 $\mu$ A rms
MSK 10-10M	Kepco	0 to 10 VDC, 0 to 10 ADC	CV $\leq$ 0.01%; CC $\leq$ 0.01%	CV $\leq$ 0.01%; CC $\leq$ 0.01%	CV $\leq$ 0.01%; CC $\leq$ 0.05%	CV 0.2 mV rms, 3 mV p-p; CC 0.02% rms, 0.1% p-p
MSK 20-5M	Kepco	0 to 20 VDC, 0 to 5 ADC	CV $\leq$ 0.01%; CC $\leq$ 0.01%	CV $\leq$ 0.01%; CC $\leq$ 0.01%	CV $\leq$ 0.01%; CC $\leq$ 0.05%	CV 0.2 mV rms, 3 mV p-p; CC 0.02% rms, 0.1% p-p
PAB160-0.4	Kikusui	0 to 160 VDC, 0 to 0.4 ADC	CV 0.02% + 2 mV DC; CC 0.02% + 2 mA DC	CV 0.02% + 2 mV DC; CC 0.02% + 2 mA DC	CV 0.02% + 3 mV DC; CC 0.02% + 3 mA DC	CV 2 mV rms
PAD 55-3L	Kikusui	0 to 55 VDC, 0 to 3 ADC	CV 0.005% + 1 mV DC; CC 1 mA DC	CV 0.005% + 1 mV DC; CC 1 mA DC	CV 0.005% + 1 mV DC; CC 2 mA DC	CV 500 mV rms; CC 1 mA rms

**APPENDIX A (Cont.)**

<b>Model, P/N or Type</b>	<b>Mfg</b>	<b>Rating</b>	<b>Line (Max)</b>	<b>Regulation</b>	<b>Load (Max)</b>	<b>Ripple</b>
PD56-10	Kenwood	0 to 56 VDC, 0 to 10 ADC	CV 0.005% + 1 mV DC; CC 3 mA DC	CV 0.005% + 1 mV DC; CC 3 mA DC	CV 0.005% + 2 mV DC; CC 5 mA DC	CV 0.5 mV rms; CC 3 mA rms
PD56-6D	Kenwood	0 to 56 VDC, 0 to 6 ADC	CV 0.005% + 1 mV DC; CC 5 mA DC	CV 0.005% + 1 mV DC; CC 5 mA DC	CV 0.005% + 1 mV DC; CC 5 mA DC	CV 0.5 mV rms; CC 2 mA rms
PE1649	Phillips	0 to 150 VDC, 0 to 23 ADC	CV ±15 mV DC; CC ±2 mA DC	CV ±15 mV DC; CC ±2 mA DC	CV ±15 mV DC; CC ±2 mA DC	CV 10 mV rms maximum
PPS-4A	Astron	0 to 16 VDC, 0 to 4 ADC; Mtr Acc: ±3 dgts	CV <±0.02% + 2 mV DC; CC <±0.5% + 250 µA DC	CV <±0.02% + 2 mV DC; CC <±0.5% + 250 µA DC	CV <±0.02% + 2 mV DC; CC <±0.05% + 250 µA DC	CV <1 mV rms (20 Hz to 20 MHz); CC <4 mA rms
PPS-50-1.5	PPM Inc.	0 to 50 VDC, 0 to 1.5 ADC; Mtr Acc: ±3% FS	CV ≤0.01% + 2 mV DC; CC ≤0.01% + 250 µA DC	CV ≤0.01% + 2 mV DC; CC ≤0.01% + 250 µA DC	CV ≤0.01% + 2 mV DC; CC ≤0.01% + 250 µA DC	CV ≤200 µV rms, 1 mV p-p; CC ≤500 µA rms
PR40-5-01-09	Mid- Eastern Industries Inc.	0 to 40 VDC, 0 to 5 ADC; Mtr Acc: ±2% FS	CV 0.01%; CC 0.01%	CV 0.01%; CC 0.01%	CV 0.01%; CC 0.25%	CV 1 mV rms
PR40-10A- 06 SPB998	Mid- Eastern Industries Inc.	0 to 40 VDC; 0 to 10 ADC	CV 0.01%; CC 0.01%	CV 0.01%; CC 0.01%	CV 0.01%; CC 0.25%	CV 1 mV rms

## APPENDIX A (Cont.)

Model, P/N or Type	Mfg	Rating	Line (Max)	Regulation	Load (Max)	Ripple
PSV-5	CSI/Speco	0 to 30 VDC, 3 ADC; Mtr Acc: $\pm 2.5\%$ FS	(108 to 132 VAC) CV $\pm 0.025\%$ + 2 mV DC		(1 to 100% Load) CV $\pm 0.25\%$ + 3 mV DC	CV Less than 5 mV p-p, to 10 kHz
PS2521G	Tektronix	0 to 6 VDC, 0 to 5 ADC Dual: 0 to 20 VDC, 0 to 25 ADC Mtr Acc: V $\pm(0.05\% + 25 \text{ mV DC})$ ; C $\pm(0.2\% + 10 \text{ mA DC})$	CV 3 mV DC; CC 3 mA DC  CV 3 mV DC; CC 3 mA DC		CV 3 mV DC; CC 3 mA DC  CV 3 mV DC; CC 3 mA DC	CV 1 mV rms or 3 mV p-p; CC 5 mA rms  CV 1 mV rms or 3 mV p-p; CC 3 mA rms
PS280	Tektronix	Dual 0 to 30 VDC, 0 to 2 ADC; Mtr Acc: $\pm(0.5\%$ rdg + 2 dgts); 5 VDC, 3 ADC	(108 to 132 VAC) CV 0.01% + 3 mV DC; CC 0.2% + 3 mA DC		CV 0.01% + 3 mV DC; CC 0.2% + 3 mA DC	CV 1 mV rms; CC 3 mA rms
PS281	Tektronix	0 to 30 VDC, 0 to 3 ADC; Mtr Acc: $\pm(0.5\%$ rdg + 2 dgts)	CV 5 mV DC  (108 to 132 VAC) CV 0.01% + 3 mV DC; CC 0.2% + 3 mA DC		CV 0.2%  CV 0.01% + 3 mV DC; CC 0.2% + 3 mA DC	CV 2 mV rms  CV 0.5 mV rms; CC 3 mA rms
PS402	Sencore	0 to 30 VDC, 0 to 3 ADC; Mtr Acc: $\pm(0.5\%$ rdg + 2 dgts); 5 VDC, 3 ADC; Output Acc: $\pm 0.25$ VDC	(108 to 132 VAC) CV $\leq 0.01\%$ + 3 mV DC; CC $\leq 0.2\%$ + 3 mA DC		CV $\leq 0.01\%$ + 3 mV DC; CC $\leq 0.02\%$ + 3 mA DC	CV $\leq 1$ mV rms, 5 Hz to 1 MHz; CC $\leq 3$ mA rms
			CV $\leq 5$ mV DC		CV $\leq 10$ mV DC	CV $\leq 2$ mV rms



APPENDIX A (Cont.)

Model, P/N or Type	Mfg	Rating	Line (Max)	Regulation	Load (Max)	Ripple
PVC50-0.5	NJE	Dual 0 to 50 VDC, 0 to 0.5 ADC; Mtr Acc: ±3% FS	(105 to 130 VAC) CV <0.005%; CC <0.01% or 50 µA DC *1	CV <0.01% + 1 mV DC; CC <0.01% or 6 mA DC *1	CV 250 µV rms (DC to 10 MHz)	
PW18-1T	Kenwood	0 to ±18 VDC, 0 to ±1 ADC; 0 to +6 VDC, 0 to +5 ADC; Mtr Acc: VDC ±(0.5% rdg + 2 dgts); ADC ±(1.0% rdg + 2 dgts)	CV 1 mV DC; CC N/A; CV 2 mV DC; CC N/A	CV 2 mV DC; CC N/A; 5 mV DC; N/A	CV 2.8 mV rms; CC N/A; CV 5.6 mV rms; CC N/A	
PW18-3A	Kenwood	0 to ±18 VDC, 0 to ±3 ADC; Mtr Acc: VDC ±2.5% FS ADC ±2.5% FS	CV 3.8 mV DC CC 2 mA DC	CV 3.8 mV DC CC 10 mA DC	CV 0.5 mV rms, 2 mV p-p; CC 6 mA rms, 12 mA p-p	
P030PX4	Acopian	0 to 30 VDC, 0 to 4 ADC	CV ±0.005% or 2 mV DC *1; CC ±0.1% or 2 mA DC *1	CV ±0.005% or 2 mV DC *1; CC ±0.2% or 5 mA DC *1	CV 0.25 mV rms; CC 0.1%	
QRD 20-4 *5	Sorensen	0 to 20 VDC, 0 to 4 ADC; Mtr Acc: ±3% FS	CV ±0.005% or ±0.75 mV DC *1; CC ±0.01% + 250 µA DC	CV ±0.005% or ±0.75 mV DC *1; CC ±0.01% + 250 µA DC	(50 to 60 Hz only) CV ≤0.5 mV rms; CC 400 µA rms (10 Hz to 7 MHz); 2 mA p-p (0 to 25 MHz)	

See footnotes at end of Table.

## APPENDIX A (Cont.)

Model, P/N or Type	Mfg	Rating	Line (Max)	Regulation	Load (Max)	Ripple
RE40-5	Electronic Measurements	0 to 36 VDC, 0 to 5 ADC; Mfr Acc: $\pm 2\%$ FS	CV 0.01% or 2 mV DC <sup>*1</sup>	CV 0.01% or 2 mV DC <sup>*1</sup>	CV 0.01% or 2 mV DC NL to FL <sup>*1</sup>	CV Less than 500 $\mu$ V rms positive or negative ground
RS20-20B	Systron Donner	0 to 20 VDC; 0 to 20 ADC	CV 0.01% or 3 mV DC <sup>*1</sup> ; CC 0.5%	CV 0.01% or 3 mV DC <sup>*1</sup> ; CC 0.5%	CV 0.01% or 3 mV DC <sup>*1</sup> ; CC 0.5%	CV less than 0.5 mV rms; CC 0.25% or 5 mA rms <sup>*1</sup>
RS40-15B	Systron Donner	0 to 40 VDC, 0 to 15 ADC	CV 0.01% or 3 mV DC <sup>*1</sup> ; CC 0.5%	CV 0.01% or 3 mV DC <sup>*1</sup> ; CC 0.5%	CV 0.01% or 3 mV DC <sup>*1</sup> ; CC 0.5%	CV less than 0.5 mV rms; CC 0.25% or 5 mA rms <sup>*1</sup> ;
RS60-12B	Systron Donner	0 to 60 VDC, 0 to 12 ADC	CV 0.01% or 3 mV DC <sup>*1</sup> ; CC 0.5%	CV 0.01% or 3 mV DC <sup>*1</sup> ; CC 0.5%	CV 0.01% or 3 mV DC <sup>*1</sup> ; CC 0.5%	CV less than 0.5 mV rms; CC 0.25% or 5 mA rms <sup>*1</sup>
RS160-4B	Systron Donner	0 to 160 VDC, 0 to 4 ADC	CV 0.01% or 3 mV DC <sup>*1</sup> ; CC 0.5%	CV 0.01% or 3 mV DC <sup>*1</sup> ; CC 0.5%	CV 0.01% or 3 mV DC <sup>*1</sup> ; CC 0.5%	CV less than 0.5 mV rms; CC 0.25% or 5 mA rms <sup>*1</sup>
R6127	Acopian	0 to 28 VDC, 0 to 25 ADC	CV $\pm 0.05\%$ ; CC $\pm 0.05\%$	CV $\pm 0.05\%$ ; CC $\pm 0.05\%$	CV $\pm 0.05\%$ ; CC $\pm 0.05\%$	CV 1 mV rms
SBC 519	Philips	0 to 27 VDC, 0 to 3 ADC	CV 0.5% at 27 VDC/2.5 ADC $\pm 1$ input line variation; 0 to 3 ADC, normal line voltage	CV 0.5% at 27 VDC/2.5 ADC $\pm 1$ input line variation; 0 to 3 ADC, normal line voltage	CV <0.05% NL to FL	CV <10 mV rms
SYR36-25-5133	Systron	0 to 40 VDC, 0 to 25 ADC	CV $\pm 0.05\%$ + 2 mV DC CC $\pm 0.25\%$	CV $\pm 0.05\%$ + 2 mV DC CC $\pm 0.25\%$	CV $\pm 0.05\%$ + 2 mV DC; CC $\pm 0.25\%$	CV 95 mV rms
SYR75-6.5PD	Systron	0 to 75 VDC, 0 to 6.5 ADC	CV 0.5% + 2 mV DC over full AC input range; CC 0.25% over full AC input range	CV 0.5% + 2 mV DC over full AC input range; CC 0.25% over full AC input range	CV 0.5% + 2 mV DC over 0 to full load range; CC 0.25% over 0 to full load range	CV 150 mV rms; CC 15 mA rms

See footnotes at end of Table.

APPENDIX A (Cont.)

Model, P/N or Type	Mfg	Rating	Line (Max)	Regulation	Load (Max)	Ripple
SYR75-6.5-5 5139	Syston	0 to 75 VDC; 0 to 6.5 ADC	CV 0.5% + 2 mV DC over full AC input; CC 0.25% over full AC range	CV 0.05% + 2 mV DC over 0 to full load range; CC 0.25% over 0 to full load range	CV 150 mV rms; CC 13 mA rms	
TCR 30	Electronic Measure- ments, Inc.	0 to 30 VDC; 0 to 100 ADC	CV $\pm 0.1\%$ ; CC $\pm 0.1\%$	CV $\pm 0.1\%$ ; CC $\pm 0.1\%$	CV 15 mV rms or less	
TCR 300S2	Electronic Measure- ments, Inc.	0 to 300 VDC, 0 to 2 ADC	CV $\pm 0.1\%$ ; CC $\pm 0.25\%$	CV $\pm 0.1\%$ ; CC $\pm 0.25\%$	CV 500 mV rms; CC 3 mA rms	
TCR 40S25-1D	Electronic Measure- ments, Inc.	0 to 40 VDC, 0 to 25 ADC	CV $< 0.1\%$ ; CC $< 0.25\%$	CV $< 0.1\%$ ; CC $< 0.25\%$	CV 60 mV rms; CC 60 mA rms	
TCR 500T10- D-0V	Electronic Measure- ments, Inc.	0 to 500 VDC, 0 to 5 ADC	CV 0.1% of maximum voltage rating Line Volts 190 to 253; CC 0.1% of maximum current rating	CV 0.1% of maximum voltage rating; CC 0.1% of maximum current rating	CV 125 mV rms	
TCR 60S10-1	Electronic Measure- ments, Inc.	0 to 60 VDC, 0 to 10 ADC	CV $< 0.1\%$ ; CC $< 0.25\%$	CV $< 0.1\%$ ; CC $< 0.25\%$	CV 120 mV rms CC 18 mA rms	

## APPENDIX A (Cont.)

Model, P/N or Type	Mfg	Rating	Line (Max)	Regulation	Load (Max)	Ripple
TP340	Power Design	A & B Outputs DC+ to COM; 0 to 32 VDC, 0 to 1 ADC; DC- to COM; 0 to -32 VDC, 0 to -1 ADC	CV 0.01% + 0.5 mV DC Current Limit 2% to 105%	CV 0.01% + 0.5 mV DC Current Limit 2% to 105%	CV 0.01% + 1 mV DC/Amp, Current Limit 2% to 105%	CV 1 mV p-p
TP840	Power Design	C Output 0 to 6 VDC, 0 to 5 ADC; 0 to 15 VDC, 0 to 2.5 ADC	C Output CV 0.01% + 0.5 mV DC Current Limit 2% to 105%	CV $\pm 0.01\%$ + 0.5 mV DC	C Output CV 0.01% + 1 mV DC/Amp, Current Limit 2% to 105%	C Output CV 1 mV p-p
TW5005D	Power Design	A and B Outputs 0 to 50 VDC, 0 to 500 mA DC; Meter Acc: $\pm 2\%$ FS	CV $\pm 0.01\%$ + 0.5 mV DC	CV $\pm 0.01\%$ + 1 mV DC/Amp	CV $\pm 0.01\%$ + 1 mV DC/Amp	CV 1 mv p-p
			CV $\pm 0.02\%$ + 0.5 mV DC	CV 0.005% + 1 mV DC at front and rear terminals; CC 0.06%	CV 0.005% + 1 mV DC at front and rear terminals; CC 0.06%	CV 350 $\mu$ Vrms/ 1 mV p-p; CC 0.3 mA p-p

APPENDIX A (Cont.)

Model, P/N or Type	Mfg	Rating	Line (Max)	Regulation	Load (Max)	Ripple
TW6050D	Power Design	Dual Each 0 to 60 VDC, 1 ADC or 0 to 25 VDC, 2 ADC or 0 to 15 VDC, 3 ADC or 0 to 6 VDC, 5 ADC; Mtr Acc: $\pm 3\%$ FS	CV 0.005%; CC 0.02%		CV 0.005%; CC 0.02%	CV 1 mV p-p; CC 5 mA p-p
V28PT10FH	Acopian	28 VDC $\pm 0.5$ VDC, 0 to 10 ADC; Mtr Acc: $\pm 2\%$ FS	CV $\pm 0.005\%$ or 2 mV DC * <sup>1</sup>		CV $\pm 0.005\%$ or 2 mV DC * <sup>1</sup>	CV <0.25 V rms
WP-704A	Vector-Vid	0 to 40 VDC, 0 to 250 mA DC	(110 to 135 VAC) CV 15 mV DC		CV <20 mV DC change for a 250 mA DC load change	CV <500 $\mu$ V rms
WP-707B	Vector-Vid	0 to 32 VDC, 0 to 5 ADC; Mtr Acc: $\pm 3$ dgts	CV $\pm 0.02\%$ + 2 mV DC; CC $\pm 0.5\%$ + 250 $\mu$ A DC, Line Variation $\pm 10\%$		CV $\pm 0.02\%$ + 2 mV DC CC $\pm 0.5\%$ + 250 $\mu$ A DC	CV 1 mV rms max; CC 2 mA rms max
WP718	Vector-Vid	0 to 36 VDC, 0 to 20 ADC; Mtr Acc: $\pm 3$ dgts	CV $< \pm (0.01\% + 2 \text{ mV DC})$ ; CC $< \pm (0.05\% + 10 \text{ mA DC})$ Line Variation $\pm 10\%$		CV $< \pm (0.01\% + 2 \text{ mV DC})$ ; CC $< \pm (0.05\% + 10 \text{ mA DC})$	CV <1 mV rms max (20 Hz to 20 MHz) CC <5 mA rms max
WP-75	Vector-Vid	0 to 50 VDC, 0 to 2 ADC; Mtr Acc: $\pm (0.5\%$ FS + 1 dgt)	CV $\pm 0.05\%$ + 3 mV DC; CC $\pm 0.05\%$ + 500 $\mu$ A DC, Line Variation $\pm 10\%$		CV $\pm 0.05\%$ + 3 mV DC; CC $\pm 0.05\%$ + 300 $\mu$ A DC	CV <1 mV rms CC <1 mA rms

See footnotes at end of Table.

## APPENDIX A (Cont.)

Model, P/N or Type	Mfg	Rating	Line (Max)	Regulation	Load (Max)	Ripple
WP-78	Vector-Vid	Dual: 0 to 30 VDC, 0 to 5 ADC; 0 to 5 VDC, 0 to 3 ADC; Mtr Acc: (V & C) ±(0.5% rdg + 2 dgts)	CV 0.02% + 3 mV DC; CV 0.02% + 3 mV DC	CV 0.02% + 3 mV DC; CV 0.02% + 3 mV DC	CV 0.02% + 3 mV DC; CV 0.02% + 3 mV DC	CV 0.05 mV rms; CV 0.5 mV rms
XTS60-1	Sorensen/ Raytheon	0 to 60 VDC, 1.0 ADC; Mtr Acc: ±(1% FS + 1 dgt)	CV 0.01% + 2 mV DC; CC 0.01% + 250 µA DC; (103.5 to 126.5 VAC)	CV 0.01% + 2 mV DC; CC 0.01% + 250 µA DC; (Remote Sense 0 to 100%) (Local Sense 10 to 100%)	CV 0.01% + 2 mV DC; CC 0.01% + 250 µA DC; (Remote Sense 0 to 100%) (Local Sense 10 to 100%)	CV 1 mV rms maximum; CC 2 mA rms
XTS120-0.5	Sorensen/ Raytheon	0 to 120 VDC, 0.5 ADC; Mtr Acc: ±(1% FS + 1 dgt)	CV 0.01% + 2 mV DC; CC 0.01% + 250 µA DC; (103.5 to 126.5 VAC)	CV 0.01% + 2 mV DC; CC 0.01% + 250 µA DC; (Remote Sense 0 to 100%) (Local Sense 10 to 100%)	CV 0.01% + 2 mV DC; CC 0.01% + 250 µA DC; (Remote Sense 0 to 100%) (Local Sense 10 to 100%)	CV 1 mV rms maximum; CC 2 mA rms
150-2-110	Electronic Measure- ments, Inc.	0 to 150 VDC, 0 to 2 ADC	CV 0.1%; CC 0.25%	CV 0.1%; CC 0.25%	CV 0.1%; CC 0.25%	CV 300 mV rms or 0.1% *1; CC 4.5 mA rms or 0.25% *1
1630	B & K Precision	0 to 30 VDC, 0 to 3 ADC; Mtr Acc: (V & A) ±2.5% FS	(110 to 130 VAC) CV ≤0.02% + 2 mV DC; CC ≤9 mA DC	CV ≤0.02% + 2 mV DC; CC ≤9 mA DC	CV ≤0.02% + 3 mV DC; CC ≤9 mA DC	CV ≤1 mV rms, ≤2 mV p-p
1635	B & K Precision	0 to 30 VDC, 0 to 3 ADC; Mtr Acc: ±(0.5% rdg + 2 dgts)	(110 to 130 VAC) CV ≤0.02% + 2 mV DC; CC 9 mA DC max	CV ≤0.02% + 2 mV DC; CC 9 mA DC max	CV ≤0.02% + 3 mV DC; CC 9 mA DC max	CV ≤1 mV rms, ≤2 mV p-p

APPENDIX A (Cont.)

Model, P/N or Type	Mfg	Rating	Line (Max)	Regulation	Load (Max)	Ripple
1635A	B & K Precision	0 to 30 VDC, 0 to 3 ADC; Mtr Acc: $\pm(0.5\%$ rdg + 2 dgts)	(108 to 132 VAC) CV 0.01% + 3 mV DC; CC 0.2% + 3 mA DC		CV 0.01% + 3 mV DC; CC 0.2% + 3 mA DC	CV $\leq 1$ mV rms, $\leq 2$ mV p-p
1646	B & K Precision	0 to 16 VDC, 0 to 10 ADC; Mtr Acc: (V & A) $\pm 5\%$ FS	(108 to 132 VAC) CV $\pm(0.2\%$ + 2 mV DC); (108 to 132): CC $\pm(0.4\%$ + 5 mA DC)		CV $\pm(0.04\%$ + 2 mV DC); CC $\pm(0.4\%$ + 5 mA DC)	CV $\leq 1$ mV rms (8 mV p-p); CC $\leq 1$ mA rms (8 mA p-p)
1651	B & K Precision	A & B 0 to 24 VDC, 0 to 0.5 ADC; C 5 VDC $\pm 100$ mV DC, 0 to 4 ADC; Mtr Acc: A & B (only) (V & A) 2.5% FS	(108 to 132 VAC) CV 0.01% + 3 mV DC; CC 0.2% + 3 mA DC		CV 0.01% + 3 mV DC; CC 0.2% + 6 mA DC	CV 1 mV rms; CC 3 mA rms
1660	B & K Precision	Dual 0 to 30 VDC, 0 to 2 ADC; 4 to 6.5 VDC, 0 to 5 ADC; Mtr Acc: $\pm(0.5\%$ rdg + 2 dgts)	CV 5 mV DC		CV 10 mV DC	CV 2 mV rms
1686	B & K Precision	3 to 14 VDC, 0 to 12 ADC; Mtr Acc: $\pm 7\%$ FS	0 to 30 VDC; (108 to 132 VAC): CV $\leq 0.01\%$ + 3 mV DC; CC $\leq 0.2\%$ + 3 mA DC; 4 to 6.5 VDC: CV $\leq 10$ mV DC		0 to 30 VDC; CV $\leq 0.01\%$ + 3 mV DC; CC $\leq 0.2\%$ + 3 mA DC; 4 to 6.5 VDC: CV (0 to 5 ADC) $\leq 10$ mV DC	0 to 30 VDC; CV $\leq 3$ mV rms; 4 to 6.5 VDC: CV $\leq 2$ mV rms

## APPENDIX A (Cont.)

Model, P/N or Type	Mfg	Rating	Line (Max)	Regulation	Load (Max)	Ripple
1711	B & K Precision	0 to 60 VDC, 0 to 2 ADC; 0 to 0.5 ADC; Mtr Acc: $\pm 2.5\%$ FS	(108 to 132 VAC) CV 0.01% + 3 mV DC; CC 0.2% + 3 mA DC	CV <0.01% + 3 mV DC; CC <0.2% + 3 mA DC	CV <0.01% + 3 mV DC CC <0.2% + 3 mA DC	CV <1 mV rms
1730	B & K Precision	0 to 30 VDC, 0 to 3 ADC; 0 to 0.5 ADC; Mtr Acc: (V & A) $\pm 2.5\%$ FS	(108 to 132 VAC) CV 0.01% + 3 mV DC; CC 0.2% + 3 mA DC	CV 0.01% + 3 mV DC; CC 0.2% + 3 mA DC	CV 0.01% + 3 mV DC; CC 0.2% + 3 mA DC	CV 1 mV rms
1735	B & K Precision	0 to 30 VDC, 0 to 3 ADC Mtr Acc: (V and A) $\pm(0.5\%$ rdg + 2 dgts)	CV 0.01% + 3 mV DC; CC 0.2% + 3 mA DC	CV 0.01% + 3 mV DC; CC 0.2% + 3 mA DC	CV 0.01% + 3 mV DC CC 0.2% + 3 mA DC	CV 1 mV rms
1743	B & K Precision	0 to 35 VDC, 0 to 6 ADC Mtr Acc: (V and A) $\pm(0.5\%$ rdg + 2 dgts)	(108 to 132 VAC) CV $\leq 0.2\%$ + 2 mV DC CC $\leq 0.4\%$ + 5 mA DC	CV $\leq 0.04\%$ + 2 mV DC CC $\leq 0.4\%$ + 5 mA DC	(108 to 132 VAC) CV $\leq 0.04\%$ + 2 mV DC CC $\leq 0.4\%$ + 5 mA DC	CV $\leq 1$ mV rms
1760	B & K Precision	A & B: 0 to 30 VDC, 0 to 2 ADC; C: 4 to 6.5 VDC, 0 to 5 ADC; Mtr Acc: (V & A) A, B, C $\pm(0.5\%$ rdg + 2 dgts)	(108 to 132 VAC) CV 0.01% + 3 mV DC; CC 0.2% + 3 mA DC	CV 0.01% + 3 mV DC; CC 0.2% + 3 mA DC	CV 0.01% + 3 mV DC; CC 0.2% + 3 mA DC	CV 1 mV rms CC 3 mA rms at 108 VAC CV 2 mV rms



APPENDIX A (Cont.)

Model, P/N or Type	Mfg	Rating	Line (Max)	Regulation	Load (Max)	Ripple
20300B	Energy Con	0 to 25 VDC, 0 to 1.2 ADC; 12.6 VAC (fix), 2 AAC; Mtr Acc: ±2% FS	0 to 25 VDC; CV 0.05%		0 to 25 VDC; CV 0.1%	0 to 25 VDC; CV 5 mV rms
20320B	Energy Con	0 to 25 VDC, 0 to 1.2 ADC; 12.6 VAC (fix), 2 AAC; Mtr Acc: ±2%	0 to 25 VDC; CV 0.05%		0 to 25 VDC; CV 0.1%	0 to 25 VDC; CV 5 mV rms
212AMK	Electronic Measurements, Inc.	0 to 100 VDC, 0 to 100 mA DC	CV 0.01% or 3 mV DC *1		CV 0.01% or 3 mV DC *1	CV 0.5 mV rms
28PT10AF	Acopian	28 VDC ±0.5 VDC, 0 to 10 ADC; Mtr Acc: ±2% FS	CV +0.005% or 2 mV DC *1		CV +0.005% or 2 mV DC *1	CV <0.25 V rms
30-33-1-D-IC	Electronic Measurements, Inc.	0 to 30 VDC, 0 to 33 ADC;	CV 0.1%; CC 0.1%		CV 0.01%; CC 0.1%	CV 75 mV p-p
3005B	Protek	0 to 30 VDC, 0 to 5 ADC; Display Acc: ±(0.5% rdg + 1 dgt)	CV 0.02% + 2 mV DC; CC 0.05% + 0.25 mA DC		CV 0.02% + 2 mV DC CC 0.05% + 5 mA DC	CV 0.2 mV rms, 4 mV p-p; CC 2 mA rms, 10 mA p-p

See footnotes at end of Table.

## APPENDIX A (Cont.)

Model, P/N or Type	Mfg	Rating	Line (Max)	Regulation	Load (Max)	Ripple
3032B	Protek	0 to 30 VDC, 0 to 3 ADC; Display Acc: $\pm(0.5\% \text{ rdg} + 1 \text{ dgt})$	CV $\leq 0.02\% + 2 \text{ mV DC}$ ; CC $\leq 0.05\% + 0.25 \text{ mA DC}$	CV $\leq 0.02\% + 2 \text{ mV DC}$ ; CC $\leq 0.05\% + 0.25 \text{ mA DC}$	CV $\leq 0.02\% + 2 \text{ mV DC}$ ; CC $\leq 0.05\% + 5 \text{ mA DC}$	CV $\leq 0.2 \text{ mV rms}$ , 4 mV p-p; CC $\leq 2 \text{ mA rms}$ , 10 mA p-p
3101-3610	Power Ten Inc.	0 to 36 VDC, 0 to 10 ADC	CV 0.05%; CC 1%; Line Volts, 105 to 125 VAC		CV 0.1%; CC 1%	CV 36 mV rms
3101A-3610	Power Ten Inc.	0 to 36 VDC, 0 to 10 ADC	CV 0.05%; CC 1%		CV 0.1%; CC 1%	CV 36 mV rms
3300D-4015	Power Ten Inc.	0 to 40 VDC, 0 to 15 ADC	CV 0.1%; CC 0.1%		CV 0.1%; CC 0.1%	CV 30 mV rms; CC 30 mA rms
3300D-6010	Power Ten Inc.	0 to 60 VDC, 0 to 10 ADC	CV 0.1%; CC 0.1%		CV 0.1%; CC 0.1%	CV 30 mV rms; CC 30 mA rms
3300D-7.575	Power Ten Inc.	0 to 7.5 VDC, 75 ADC	CV 0.1%; CC 0.1%		CV 0.1%; CC 0.1%	CV 30 mV rms; CC 30 mA rms
3302D	Topward Ele. Inst.	0 to 30 VDC, 0 to 2 ADC Mtr Acc: $\leq(0.1\% + 2 \text{ dgts})$	(108 to 132 VAC) CV $\pm 0.01\% + 2 \text{ mV DC}$ ; CC $\pm 0.01\% + 2 \text{ mA DC}$		CV $\pm 0.01\% + 2 \text{ mV DC}$ ; CC $\leq 10 \text{ mA DC}$	CV $\leq 0.5 \text{ mV rms}$ ; CC $\leq 1 \text{ mA rms}$
3303D	Topward Ele. Inst.	0 to 30 VDC, 0 to 3 ADC; Mtr Acc: $\leq(0.1\% + 2 \text{ dgts})$	CV $\pm 0.01\% + 2 \text{ mV DC}$ ; CC $\pm 0.01\% + 2 \text{ mA DC}$		CV $\pm 0.01\% + 2 \text{ mV DC}$ ; CC $\leq 10 \text{ mA DC}$	CV $\leq 0.5 \text{ mV rms}$ ; CC $\leq 1 \text{ mA rms}$
3306D	Topward Ele. Inst.	0 to 30 VDC, 0 to 6 ADC; Mtr Acc: $\leq(0.1\% + 2 \text{ dgts})$	CV $\pm 0.01\% + 2 \text{ mV DC}$ ; CC $\pm 0.01\% + 2 \text{ mA DC}$		CV $\pm 0.01\% + 2 \text{ mV DC}$ ; CC $\leq 10 \text{ mA DC}$ at $\leq 100 \text{ W}$ , $\leq 15 \text{ mA DC}$ $\geq 100 \text{ W}$	CV $\leq 0.5 \text{ mV rms}$ at $\leq 100 \text{ W}$ , $\leq 1 \text{ mV rms}$ $\geq 100 \text{ W}$ CC $\leq 1 \text{ mA rms}$ at $\leq 100 \text{ W}$ , $\leq 3 \text{ mA rms}$ $\geq 100 \text{ W}$

**APPENDIX A (Cont.)**

<b>Model, P/N or Type</b>	<b>Mfg</b>	<b>Rating</b>	<b>Line (Max)</b>	<b>Regulation</b>	<b>Load (Max)</b>	<b>Ripple</b>
3410D-4025	Power Ten	0 to 45 VDC, 0 to 25 ADC	CV 0.1%; CC 0.1%		CV 0.1%; CC 0.1%	CV 30 mV rms
3413D-1202.5	Power Ten Inc.	0 to 5 VDC, 0 to 1 mA DC	CV 0.1% of max output; CC 0.1% of max output voltage		CV 0.1% of max output; CC 0.1% of max voltage output	CV 50 mV maximum
40-125-2-D	Electronic Measurements Inc.	0 to 40 VDC *4, 0 to 125 ADC; Mtr Acc: ±2% FS	CV <0.1%; CC <0.1%		CV <0.1%; CC <0.1%	CV 75 mV p-p;
40S25-1	Electronic Measurements Inc.	0 to 40 VDC, 0 to 25 ADC; Mtr Acc: ±2%	CV 1%; CC 25%		CV 1%; CC 25%	CV 60 mV rms; CC 60 mA rms
4010	Power Ten Inc.	0 to 40 VDC, 0 to 10 ADC	CV 0.01% + 200 µV DC; CC 0.02% + 500 µA DC		CV 0.01% + 200 µV DC; CV 0.01% + 500 µA DC	CV 200 µV rms; CC 3 mA rms
5030	Power Design	0 to 50 VDC, 0 to 3 ADC; Mtr Acc: ±2% FS	(50 VDC at 2 ADC) CV ±0.01% + (1.5 mV per amp of load current)			CV <3 mV p-p
6010D	Power Design	0 to 60 VDC, 0 to 0.5 ADC; 0 to 50 VDC, 0 to 1 ADC; 0 to 20 VDC, 0 to 1.5 ADC; Mtr Acc: ±1%	CV ±0.005% + 1 mV DC for line voltage variation ±10%; CC ±0.03%		CV ±0.005%; CC ±0.03%	CV 1 mV p-p; CC 0.5 mA p-p

See footnotes at end of Table.

## APPENDIX A (Cont.)

Model, P/N or Type	Mfg	Rating	Line (Max)	Regulation	Load (Max)	Ripple
6023A	Hewlett- Packard	0 to 20 VDC, 10 ADC max; 0 to 6.7 VDC, 30 ADC max Autorange (242 W max); Mtr Acc: 20 VDC, $\pm(0.6\%$ rdg + 20 mV DC); 200 VDC, $\pm(0.6\%$ rdg + 200 mV DC); 200 A, $\pm(0.6\%$ rdg + 200 mA DC)	CV 0.01% + 1 mV DC; CC 0.01% + 6 mA DC	CV 0.01% + 2 mV DC; CC 0.01% + 9 mA DC	CV 20 Hz to 20 MHz 3 mV rms, 30 mV p-p; CC 15 mA rms	
6028A	Hewlett- Packard	0 to 60 VDC, 3.3 ADC max; 0 to 20 VDC, 10 ADC max Autorange (240 W max); Mtr Acc: 20 VDC, $\pm(0.6\%$ rdg + 20 mV DC); 200 V $\pm(0.6\%$ rdg + 200 mV DC); 200 A $\pm(0.6\%$ rdg + 70 mA DC)	CV 0.01% + 2 mV DC; CC 0.01% + 2 mA DC	CV 0.01% + 3 mV DC CC 0.01% + 5 mA DC	CV 3 mV rms, 30 mV p-p; CC 5 mA rms	
6106A	Hewlett- Packard	0 to 100 VDC, 0 to 200 mA DC; Mtr Acc: 12 VDC, 120 VDC $\pm 3\%$ FS; 25 mA DC, 250 mA DC, $\pm 3\%$ FS	CV 0.001%	CV 0.001% + 100 $\mu$ V DC	CV 40 $\mu$ V rms, 100 $\mu$ V rms	

APPENDIX A (Cont.)

Model, P/N or Type	Mfg	Rating	Line (Max)	Regulation	Load (Max)	Ripple
6212C	Hewlett-Packard	0 to 100 VDC, 0 to 100 mA DC; Mtr Acc: ±3% FS	CV 4 mV DC		CV 8 mV DC	CV 200 μV rms, 1 mV p-p
6214C	Hewlett-Packard	0 to 10 VDC, 0 to 1 ADC; Mtr Acc: 12 VDC, 1.2 ADC, ±4% FS	CV 4 mV DC; CC 750 μA DC		CV 4 mV DC; CC 500 μA DC	CV 200 μV rms, 1 mV p-p; CC 150 μA rms, 500 μA p-p
6216C	Hewlett-Packard	0 to 25 VDC, 0.4 ADC; Mtr Acc: 30 VDC, 500 mA DC; ±3% FS	CV 4 mV DC; CC 500 μA DC		CV 4 mV DC CC 500 μA DC	CV 200 μV rms, 1 mV p-p
6479C	Hewlett-Packard	0 to 300 VDC, 0 to 35 ADC; Mtr Acc: 350 VDC, 40 ADC, ±2% FS	CV 0.05 + 100 mV DC; CC 0.1% + 35 mA DC		CV 0.05% + 100 mV DC; CC 0.1% + 35 mA DC	CV 330 mV rms, 3 V p-p
72-2010	Tenna	0 to 30 VDC, 0 to 3 ADC; Mtr Acc: Digital, ±(0.5% rdg + 2 dgts) Analog, N/A	CV 0.01% + 3 mV DC; CC 0.2% + 3 mA DC		CV 0.01% + 3 mV DC; CC 0.2% + 3 mA DC	CV ≤0.5 mV rms (5 Hz to 1 MHz); CC ≤3 mA rms
72-2075	Tenna	0 to 30 VDC, 0 to 3 ADC; Mtr Acc: Digital, ±(0.5% rdg + 2 dgts) Analog, N/A	CV 0.01% + 3 mV DC; CC 0.2% + 3 mA DC		CV 0.01% + 3 mV DC; CC 0.2% + 3 mA DC	CV 0.5 mV rms; CC 3 mA rms

## APPENDIX A (Cont.)

Model, P/N or Type	Mfg	Rating	Line (Max)	Regulation	Load (Max)	Ripple
72-2080	Tenma	0 to 30 VDC, 0 to 3 ADC; Mtr Acc: ±(0.5% rdg + 2 dgts); Analog, N/A; 5 VDC ±0.25 VDC, 3 ADC	CV 0.01% + 3 mV DC; CC 0.2% + 3 mA DC	CV 0.01% + 3 mV DC; CC 0.2% + 3 mA DC	CV 0.01% + 3 mV DC; CC 0.2% + 3 mA DC	CV 1 mV rms; CC 3 mA rms
72-6615	Tenma	Dual 0 to 30 VDC, 0 to 3 ADC; Mtr Acc: ±(0.5% rdg + 2 dgts); 5 VDC ±0.25 VDC, 3 ADC	CV ≤0.01% + 3 mV DC; CC ≤0.2% + 3 mA DC	CV ≤0.01% + 3 mV DC; CC ≤0.2% + 3 mA DC	CV ≤3 ADC, ≤0.01% + 3 mV DC; >3 ADC, ≤0.02% + 5 mV DC; CC 0.2% + 3 mA DC; CV ≤10 mV DC	CV ≤1 mV rms (5 Hz to 1 MHz); CC ≤3 mA rms  CV ≤2 mV rms
832-210	Extech	0 to 30 VDC, 0 to 3 ADC; Mtr Acc: ±(0.5% rdg + 2 dgts)	CV ≤0.02% + 3 mV DC; CC ≤0.02% + 3 mA DC	CV ≤0.02% + 3 mV DC; CC ≤0.02% + 3 mA DC	CV ≤0.02% + 3 mV DC; CC ≤0.02% + 3 mA DC	CV ≤2 mV rms; CC ≤3 mA DC
8609	Watco	0 to 50 VDC, 1.5 ADC ±5% Mtr Acc: ±(0.5% rdg + 2 dgts)	CV 0.01% + 2 mV DC; CC 0.01% + 300 mA DC	CV 0.01% + 2 mV DC; CC 0.01% + 300 mA DC	CV 0.01% + 2 mV DC; CC 0.01% + 300 mA DC	CV 1 mV p-p; CC 1 mA p-p
90074-2	Lambda	24 to 38 VDC; 0 to 10 ADC	CV 0.1%	CV 0.1%	CV 0.1%	CV 35 mV rms; CC 150 mV p-p
GPS-3030D	Instek	0 to 30 VDC, 0 to 3 ADC; Mtr Acc: Digital ±(0.5% rdg + 2 dgts)	CV ≤0.01% + 3 mV DC; CC ≤0.2% + 3 mA	CV ≤0.01% + 3 mV DC; CC ≤0.2% + 3 mA	CV ≤0.01% + 3 mV DC; CC ≤0.2% + 3 mA	CV ≤0.5 mV rms at 5 Hz to 1 MHz; CC ≤3 mA rms
LGS-FA-5-0V-R	Lambda	5 V at 190 A	CV 0.1%	CV 0.1%	CV 0.1%	10 mV rms

APPENDIX A (Cont.)

Model, P/N or Type	Mfg	Rating	Line (Max)	Regulation	Load (Max)	Ripple
LLS-6060	Lambda	0 to 60 VDC, 0 to 2.8 ADC Mtr Acc: ±2% rdg or 3 dgts, whichever is greater	CV 0.05% CC 0.3%		CV 0.05% CC 0.3%	CV 10 mV rms, 75 mV p-p; CC 1%
RAX28-6.2K	TDK	28 VDC at 6.2 ADC	CV 1.5%		CV 1.5%	Ripple, 100 mV p-p; Ripple noise, 330 mV p-p
TP343B	Power Design	A & B Outputs 0 to 20 VDC, 0 to 2.5 ADC; 0 to 25 VDC, 0 to 1 ADC	CV 0.01% + 0.5 mV DC		CV 0.01% + 1 mV DC/Amp,	CV 1 mV p-p
1101	Tektronix	+15 VDC, ±0.75% of output at 400 mA DC; -15 VDC, ±1.5% of output at 400 mA DC; +5 VDC, ±2% of output at 400 mA DC	C Output CV 0.01% + 0.5 mV DC		C Output CV 0.01% + 1 mV DC/Amp,	C Output CV 1 mV p-p
						CV ≤1 mV rms at 400 mA; CV ≤1 mV rms at 400 mA; CV ≤1 mV rms at 400 mA

## APPENDIX A (Cont.)

Model, P/N or Type	Mfg	Rating	Line (Max)	Regulation	Load (Max)	Ripple
72-4045A	Tenma	A & B Outputs 0 to 24 VDC, 0 to 0.5 ADC; Mtr Acc: $\pm 2.5\%$ FS	CV $\leq 0.01\% + 3$ mV DC CC $\leq 0.2\% + 3$ mA DC	CV $\leq 0.01\% + 3$ mV DC CC $\leq 0.2\% + 6$ mA DC	CV $\leq 0.01\% + 3$ mV DC CC $\leq 0.2\% + 6$ mA DC	CV $\leq 2$ mV rms, 5 Hz to 1 MHz; CC $\leq 3$ mA rms
		C Output 5 VDC, $\pm 100$ mV DC at $\geq 2$ ADC	CV $\leq 5$ mV DC	CV $\leq 10$ mV DC	CV $\leq 2$ mV rms, 5 Hz to 1 MHz;	

\*<sup>1</sup> Whichever is greater.

\*<sup>2</sup> Set TI switch A to the UP position and connect the load between JI-A and JI-J.

\*<sup>3</sup> Whichever is smaller.

\*<sup>4</sup> For a minimum input line current of 24.0 AAC the input line voltage is 190 to 250 VAC.  
For a minimum input line current of 25.3 AAC the input line voltage is 180 to 220 VAC.

\*<sup>5</sup> All measurements must be made at TI rear terminals.